

THE PROFESSIONAL MAGAZINE FOR ELECTRONICS AND COMPUTER SERVICING

ELECTRONICTM

Servicing & Technology

May 2000

Understanding IEEE-1394 "Firewire"

Tools and Toolcases showcase

Servicing a Philips DVD: The power supply

PROFAK
RCA/GE
Color Video Camcorder
Models CC260/280



KIRK907 787593006 2400 08 05/23/00

KIRKLAND
9200 QUAIL HILL CIR
AUSTIN TX 78758-6617



7 25274 86667 0

ONE CALL DOES IT ALL

We deliver what you need,
When you need it.

You can count
on Philips
Smart Parts



Increase profits
with Philips Smart
Accessories

Your One-Stop Shop for Replacement Parts, Accessories, and Service Aids.
Call 800-851-8885 or fax 800-535-3715.

Let's make things better.



PHILIPS

Circle (58) on Reply Card

contents

FEATURES

- 6 Understanding light and color and the operation of a color analyzer** by Stan Warner
This article explains the concepts of light and color in general and describes how to adjust a TV set's color correctly.
- 16 Camcorder servicing** by the ES&T Staff
With some of the most recent innovations in consumer electronics, the only tool you may need to service some problems is your personal computer.
- 20 Service tips software** by the ES&T Staff
Service tips software brings the collective experience of many service technicians to bear on the problem at hand.
- 24 Understanding IEEE-1394 Firewire: The new standard for multimedia data transport** by John Ross
IEEE-1394 or "Firewire," allows huge amounts of data to be sent via a single cable.
- 40 Servicing a Philips DVD: The power supply** by Bob Rose
Here's an in-depth look at the power supply of a DVD and some troubleshooting hints.
- 46 Remote profit** by John Hanson
Some new batteries and cleaning and brightening of contacts may be all it takes to restore a remote to service.
- 50 A video problem in a Zenith SR2739RK** by Bob Rose
Following the author in this troubleshooting odyssey gives the reader a good feel for the video circuits in this set.
- 54 A new twist to an old problem: Modern vertical deflections** by Bob Rose
New circuits in TVs change the way technicians service these new sets.

ADVERTISING SUPPLEMENT

12 Tools & Toolcases Showcase

This showcase gives our readers the opportunity to learn directly from the companies who advertise in this issue about the latest tools and toolcases available for consumer electronics technicians, and gives them some guidelines for selecting a tool and toolcase vendors.

DEPARTMENTS

- | | |
|--------------|----------------------|
| 2 Editorial | 23 Photofacts |
| 3 Literature | 29 Profax |
| 4 News | 59 Products |
| 10 Calendar | 63 Classified |
| 15 Books | 64 Reader's Exchange |

3

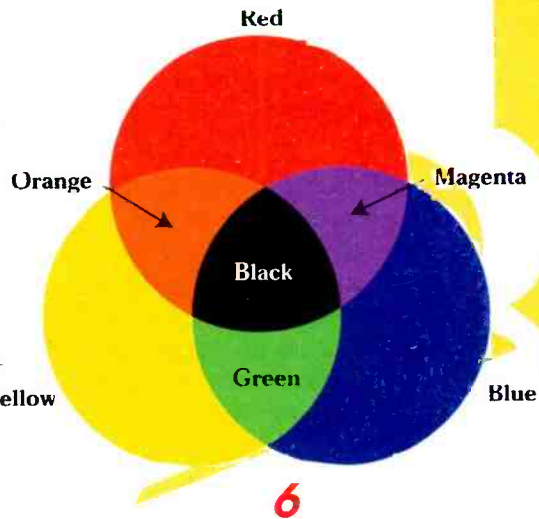

16

ON THE COVER

Every profession requires some kind of tool. The profession of consumer electronic service technician requires a broad selection of highly sophisticated tools and the knowledge and education to apply them properly.

Editorial

by Nils Conrad Persson

Residential systems integration

It's difficult to imagine what the typical home in the United States must have been like a hundred years ago. Of course there was no television; it hadn't been invented yet. Oh, and no radio either. That hadn't been invented yet either. A few wealthy homes in large populated areas might have a telephone and/or electric light, but most didn't. It goes without saying that there were no electrical appliances, no air conditioning, no automatic heating systems.

Looking at the other side of the coin, the average home dweller of 100 years ago couldn't, in his wildest imagining, have conceived of the typical home of today with its electrically-powered labor-saving devices, connection to anywhere in the world via telephone line, access to news and other information via television, radio, and the internet, meals cooking in the microwave oven, Hollywood movies playing on the VCR or DVD, wireless telephones. It almost boggles the minds of those of us who have watched them being introduced over the years.

Thinking about things in that kind of perspective makes one wonder what the home will be like a hundred years hence, and what kinds of transition are taking place today that will lead to that type of home environment. A number of things are happening right now that will change the face of the home. The Consumer Electronics Association (CEA) calls it TechHome, and speaks of integrating the functions within homes using the power of today's electronics. The concept involves a number of functions within the home. Here is what the CEA website (www.cea.org) says about integrating systems within the home.

Your home has several independent systems and dozens of individual products designed to increase comfort, safety, and convenience. Heating, air conditioning, lighting, and cable television are typical home systems. Appliances range from television sets, audio equipment and computers to coffee makers and microwave ovens. Integrated home systems link the independent systems and appliances so they can work together and be controlled from other sources. Almost every appliance and system in your home can be integrated into a larger system, thus improving its performance and convenience. In fact you can get started on your own integrated home system in one evening for less than \$25.00. The site explains the concepts, methods, and products required to create an integrated home system. The guide to integrated home systems, is divided into these five major sections:

Environmental control and energy management

- HVAC (Heating, Ventilating, and Air Conditioning)
- Powerline conditioning
- Water management

Security and access control

- Alarm systems
- Remote telephone notification
- Locks
- Surveillance

Audio/video entertainment

- Home theater
- Whole-house audio/video

Voice and data communication

- Home LAN
- Intercom
- Paging
- Multi-line phones
- High-speed Internet

Lighting and window treatments

- Drapery control
- Lighting control

These five categories of home systems describe what can be integrated and controlled through integrated home systems. A technician who is interested in installing systems for home systems integration needs to learn about the technologies that make this integration possible such as: distribution methods, structured wiring, powerline carrier, radio frequency, and the control methods involved.

What are the practical benefits? According to CEA, integrated home systems, also known as home automation, home control, and home systems, can be defined best by example: Pressing the "away" button on a keypad automatically arms the security system, turns off all lights in the house after a 10-minute delay and sets back the thermostat to an energy-saving temperature. The systems communicate with each other, and often with a central controller, to ensure that all systems are working to efficiently protect, entertain, and comfort a home's occupants.

While all of the systems mentioned above serve to integrate systems in the home, there are differences among them, and in the technologies used to implement them. Home automation has to do with interconnecting and controlling home appliances and home functions, while home networking has to do with interconnecting information processing and delivery devices. Home automation involves transferring relatively low volumes of data with no particular requirement for great speed, while home networking involves transferring large volumes of data quickly.

Consumer electronics service centers have the expertise and the equipment necessary to become involved in this revolution, and to a far greater extent than many entrepreneurs who are jumping on the bandwagon. They also have the visibility in the eyes of homeowners. For a service center whose business is dropping off, this would seem to be a natural area for them to at least explore. ■

Electronic Servicing & Technology is edited for servicing professionals who service consumer electronics equipment. This includes service technicians, field service personnel and avid servicing enthusiasts who repair and maintain audio, video, computer and other consumer electronics equipment.

EDITORIAL

Nils Conrad Persson, *Editor*
(Internet e-mail: cpersedit@aol.com)
Alycia NicholSEN, *Associate Editor*
(Internet e-mail: AlyciaEST@aol.com)
Richard S. Moseson, W2VU, *On-Line Coordinator*

CONSULTING EDITORS

Homer L. Davidson, *TV Servicing Consultant*
Victor Meeldijk, *Components Consultant*
John E. Shepler, *Audio Consultant*
Sam Wilson, *Electronics Theory Consultant*

BUSINESS

Richard A. Ross, *Publisher*
Jonathan Kummer, *Associate Publisher*
Emily Leary, *Sales Assistant*
Sal Del Grosso, *Accounting Manager*
Ann Marie DeMeo, *Accounting Department*
Judith Erickson, *Office Manager*

CIRCULATION STAFF

Catherine Ross, *Circulation Manager*
Melissa Gilligan, *Operations Manager*
Denise Kells, *Data Processing*
Jennifer Cormagi, *Customer Service*

PRODUCTION

Elizabeth Ryan, *Art Director*
Barbara McGowan, *Associate Art Director*
Edmond Pesonen, *Electronic Composition Mgr.*
Dorothy KehrwieDer, *Production Manager*
Emily Leary, *Assistant Production Manager*

EDITORIAL CORRESPONDENCE:

P.O. Box 12487
Overland Park, KS 66212
913-492-4857



National Electronics Service
NESDA
Dealers' Association, Inc.
Member, Electronic Servicing
Dealers Association

A publication of

CQ Communications, Inc.
25 Newbridge Road
Hicksville, NY 11801 USA.

Electronic Servicing & Technology (ISSN 0278-9922) is published 12 times a year by CQ Communications, Inc. 25 Newbridge Road, Hicksville, NY 11801. Telephone (516) 681-2922. Periodical class postage paid at Hicksville, NY and additional offices. Subscription prices (payable in US dollars only): Domestic—one year \$26.95, two years \$49.95. Canadian—one year \$36.95, two years \$69.95. Foreign Air Post—one year \$44.95, two years \$85.95. Entire contents copyright 2000 by CQ Communications, Inc. Electronic Servicing & Technology or CQ Communications, Inc. assumes no responsibility for unsolicited manuscripts. Allow six weeks for delivery of first issue and for change of address. Printed in the United States of America.

Postmaster: Please send change of address notice to Electronic Servicing & Technology, 25 Newbridge Road, Hicksville, NY 11801.

Literature

Crystal product data book

C-MAC Frequency Products has released its new Crystal Product Data Book 2000 containing a wide selection of frequency control products.



The 284-page data book provides detailed specifications of hundred of standard and custom frequency control devices. New quartz crystal products included in the 2000 edition include the CFPT-9100, an "all causes" Stratum surface-mount TCXO (temperature compensated crystal oscillator) based on mass-market mobile phone technology, the CFPV-2365, a low-voltage 622.0 MHz VCXO (voltage controlled crystal oscillator) for time multiplexing in SDH/SONET trunk lines and a number of ultra-high-stability OCXOs (oven controlled crystal oscillators). The book also includes information about the company's first rubidium oscillators.

C-MAC Frequency Products, 4222 Emperor Blvd., Suite 300, Durham, NC 27703-8466,

Phone: 919-941-0430, Fax: 919-941-0530, E-mail: cfp@america.cfpwww.com, Website: <http://cfpwww.com>

Circle (100) on Reply Card

Product catalog

The new Buyer's Guide Product Catalog from Hub Materials company contains a wide variety of technical supplies for designing, assembling, testing and repairing electronic products and sub-assemblies. Products include preci-



sion hand tools, soldering and desoldering supplies, static-control products, test equipment, measurement and inspection instruments, workstations and PC board handling items, adhesives and cleaning chemicals, tool cases and custom tool kits. The company has designed its new catalog so you can find what you are looking for in less time than it normally takes using other catalogs. With easy-to-understand, color-coded comparison tables of product features, and large clear photos, you can make a well-informed decision about whether a product is right for your particular application.

Hub Material Company, 33 Springdale Avenue, Canton, MA 02021, E-mail: sales@hubmaterial.com, Website: www.hubmaterial.com
Circle (101) on Reply Card

Catalog of electronic components and hardware

Keystone Electronics has released a new 104-page catalog listing its complete line of interconnect components and hardware for electronic products, instruments, and systems. Keystone's line of standard components has been expanded to include products for SMT assembly and high speed interconnection devices. Catalog items range from brackets and battery holders to PCB terminals, SMT, and THM test points, IEEE sockets and

(Continued on page 62)

Audio sales strong

Revenues from manufacturer-to-dealer sales of audio products in December totaled nearly \$568 million, a 6.3 percent increase over the previous December. The strong month's sales pushed year-end revenue totals to their highest mark in four years. Total audio shipment revenues in 1999 surpassed the \$8 billion mark for the first time since 1995.

The strongest performer in the month was the portable audio category, which grew by 16 percent over last December. Portable audio also finished the year as the leading audio category, eclipsing the \$2.4 billion mark. Home radios and headset CD players spurred the growth in the category, increasing by 4 and 6 percent respectively over 1998.

Audio systems grew by 8 percent over last December to revenues of nearly \$148 million. Audio systems revenues in 1999 also finished solidly ahead of 1998, posting a 5 percent growth to \$2.1 billion. This growth was largely fueled by compact system sales, which finished 9 percent ahead of 1998 at \$1.7 billion.

The big success story of 1999, however, was aftermarket autosound. Sales of aftermarket autosound products grew by more than 13 percent during the year, to total revenues of nearly \$2.2 billion. The growth in this segment is largely attributable to falling price points and consumers' increased desire for component additions, particularly digital technologies that reflect products in the home. Among these products, in-dash CD players experienced an especially good year, growing by an incredible 41 percent over 1998 sales to \$935 million. Other products having banner years were car speakers and amplifiers with sales increasing by 6 and 29 percent, respectively.

In the separate components category, home speaker revenues increased by 17 percent in December. The highlight in the components category, though, was sales of receivers which grew by 10 percent during the year. Specifically, Dolby Digital 5.1 channel surround sound receivers had a tremendous year, growing by 77 percent over 1998 sales.

"The strong sales of multi-channel receivers in 1999 supports our belief that consumers are continuing to seek a more complete audio experience," said Stephen Baker, chair of CEA's audio division. "In 2000, this trend will lead to quick acceptance and excellent sales of the new surround sound formats, such as DVD-Audio and Super Audio CD."

Agreement will enable consumers to receive DTV programming and services over cable systems

The Consumer Electronics Association (CEA) and the National Cable Television Association (NCTA) announced that they have reached voluntary agreements that will allow future consumer digital television (DTV) sets and digital cable systems to work together. The agreements detail the technical specifications that will enable consumers to receive DTV programming and services over cable systems.

"This is good news for cable customers contemplating a pur-

chase of a digital television receiver," said Robert Sachs, President and CEO of the NCTA. "The cable and consumer electronics industries now have specifications that ensure that signals transmitted on cable will be easily viewed on digital sets. This voluntary solution makes unnecessary government involvement in setting compatibility standards for the dynamic digital TV marketplace."

"While our industries celebrate the announcement, the true winner is the American consumer," said CEA President and CEO Gary Shapiro. "With these agreements, many more consumers will soon be able to access the wonders of digital television through cable. This is yet another giant step forward in the transition to DTV. Indeed, all parties with a true interest in the success of DTV should celebrate."

Both Shapiro and Sachs praised Chairman Kennard and the FCC for expediting industry resolution of these issues and contributing greatly to the success of the joint CEA/NCTA discussions. They also pledged their respective industries' commitment to implementing these agreements promptly and to resolving the remaining issues.

The agreements detail the technical requirements that permit the direct connection of digital television receivers to cable television systems, specifying the signal levels and quality as well as video formats. They also provide for the carriage of Program and System Information Protocol (PSIP) data on cable systems to support on-screen guide functions in digital receivers. Subject to certain conditions, PSIP data enables features such as on-screen program guides, virtual channel tables, program name and description (for a minimum 12-hour period), and content advisory information.

With roughly two-thirds of U.S. households receiving television programming via cable, these agreements mark an important milestone in the U.S. transition to digital television.

CEA is a sector of the Electronic Industries Alliance (EIA), the 76-year-old Arlington, Virginia-based trade organization representing all facets of electronics manufacturing and connecting the industries that define the digital age. CEA represents more than 600 U.S. companies involved in the development, manufacturing, and distribution of audio, video, mobile electronics, communications, information technology, multimedia and accessory products, as well as related services, that are sold through consumer channels. Combined, these companies account for more than \$60 billion in annual sales.

NCTA is the principal trade association of the cable television industry in the United States. Its members include owners and operators of cable television systems serving over 90 percent of the nation's cable television households and over 100 program networks. Its membership also includes cable equipment suppliers, and others interested in or affiliated with the cable television industry. Sachs also thanked Dr. Richard Green, President and CEO of Cable Television Laboratories, and his team for their assistance in reaching these agreements.

DTV sales top 100,000

Factory-to-dealer sales of digital television (DTV) products posted their fourth consecutive month of growth in November by topping 22,000 units, and bringing total year-to-date sales to 97,481, according to numbers released by the Consumer Electronics Association (CEA). November's record sales brought total sales since introduction (in August of 1998) to 110,657.

Actual DTV sales in November were 22,634 units, an increase of six percent over October's sales. Fourth quarter DTV sales have already reached 44,066 units, representing an increase of 67 percent over total third quarter sales, and a 303 percent over second quarter sales, with one month still remaining.

"DTV sales have taken off this quarter, pushing sales levels ahead of our projections," said Gary Shapiro, president and CEO of CEA. "There is no question that the future of television is digital. These sales figures show that more and more consumers are realizing DTV's benefits everyday."

CEA's projection that DTV products sales since introduction will reach 120,000 units by the end of 1999 appears to be on target. CEA estimates sales will reach 600,000 in the year 2000, and projects that the first 10 million sets will be sold by 2003, the next 10 million in 2004 and 2005 and 10.8 million to be sold in 2006.

CEA welcomes MSTV support for 8-VSB

The following statement was issued by Consumer Electronics Association (CEA) President and CEO Gary Shapiro in response to the announcement by the Association for Maximum Service Television (MSTV) that it will continue to back the

existing Federal Communications Commission (FCC)-approved digital TV (DTV) modulation standard, 8-VSB:

"We are pleased that MSTV — representing major U.S. broadcasters — has restated and reaffirmed its strong support for 8VSB. MSTV's test results can now be added to the reams of evidence demonstrating that 8-VSB is the best modulation standard for the United States. We again urge the FCC to accept our petition and MSTV's recommendation to dismiss Sinclair Broadcasting's request to add COFDM as an option.

"Real world experience underscores the success of 8-VSB. Retailers across the country report that consumers who have purchased DTV products and are receiving over-the-air programming are exceedingly pleased with the technology. Just recently, CEA co-hosted an event held in Baltimore, Maryland showcasing a live, over-the-air, high-definition television (HDTV) broadcast of Super Bowl XXXIV.

"The transition to DTV is moving forward at a strong pace. Already more than 100 stations are broadcasting digital signals using 8-VSB. DTV products are available at more than 200 locations across the country. In 1999, the technology's first full year on the market, more than 120,000 digital television products were sold. CEA predicts that more than five times that number will sell in 2000, with sales of 600,000 sets.

"Receiver manufacturers remain committed to ensuring that all consumers have access to over-the-air DTV. As with any new technology, receiver performance will only improve in future generations of product. We look forward to working with all interested parties to bring the promise of digital television to all consumers." ■

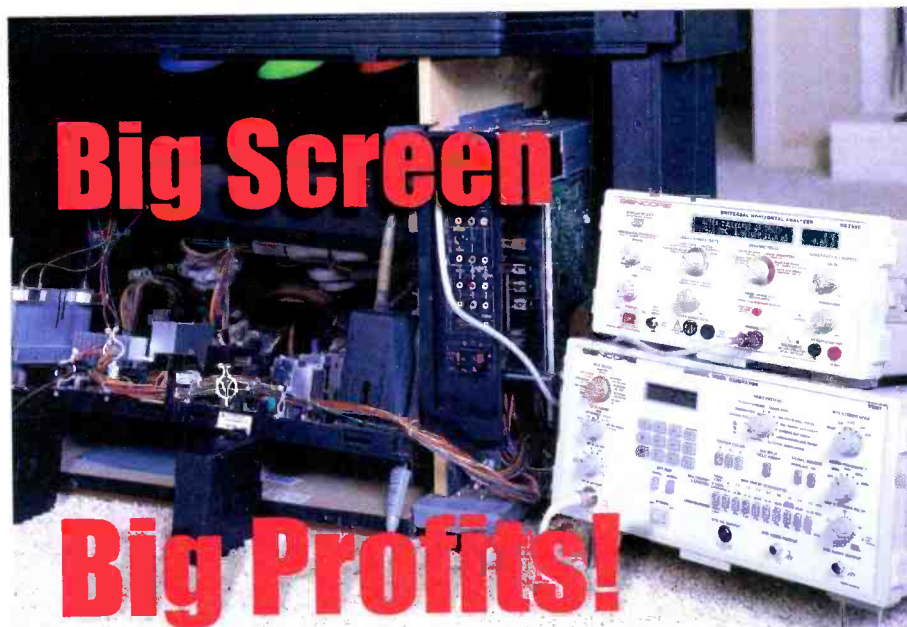

HA2500 Universal Horizontal Analyzer

Localize horizontal and B+ Supply defects in less time and more profitably than ever before!

- Exclusive "Horizontal Output Load Test" makes setup and testing a snap - even without applying AC power for faster diagnosis
- Patented "ringer" proves the condition of flybacks and yokes in seconds
- Exclusive "dynamic tests" help you analyze the horizontal circuit in powered-up conditions

VG91 Universal Video Generator

This complete all channel RF/IF/MTS Universal Video Generator performance tests and isolates defects in any NTSC video system, including big screen TV systems!

- Proof-positive tests for MTS Stereo/SAP on all channels
- Exclusive and dynamic NTSC video test signals
- Standard, Y/C, composite video, and audio line outputs

Bring home the cash with in-home servicing of high-end electronics. Quickly and accurately aligning big-ticket items like projection TVs for your customer's total viewing satisfaction can be your best opportunity for profitability. Sencore offers servicing solutions for progressive servicers with portable, durable and reliable test equipment that brings the "best of the bench" to every home.

SENCORE
1-800-SENCORE

www.sencore.com • email:sales@sencore.com

Understanding light and color and the operation of a color analyzer

by Stan Warner

It's interesting, and instructive, for a consumer electronics servicing technician to go to a large store and look at the television display area. There you'll find dozens of sets showing the same program, but there probably aren't two pictures that appear alike. The picture on some of the screens are more red, others are mainly a greenish tinge. Some pictures are brighter and some pictures are dimmer.

And these sets are brand-new units right out of the box. Imagine how far off from a proper image a set can be after it has aged for a while, and inexperienced viewers have had a chance to fiddle with the adjustment controls.

Obviously, there must be some objective standard to which all of these sets should be adjusted to produce a picture that is an accurate reproduction of the original scene. A technician who is familiar with the concepts of light and color, who knows how a CRT produces light and color, and who knows how to adjust a TV set so that it produces the best color it can, will be able to provide his customers with a high degree of viewing pleasure.

This article explains the concepts of light and color in general, and specifically regards the picture produced by a TV set. It then goes on to describe the adjustments that can be used to set the color correctly, and provides a description of a color analyzer, a device that can be used to adjust colors correctly, objectively, without the bias that the human eye can introduce.

Human vision

Light is electromagnetic energy within a narrow range of frequencies capable of causing the sensation of vision. The human eye/brain combination acts, in some respects, like a radio receiver tuned to receive this particular range of radio

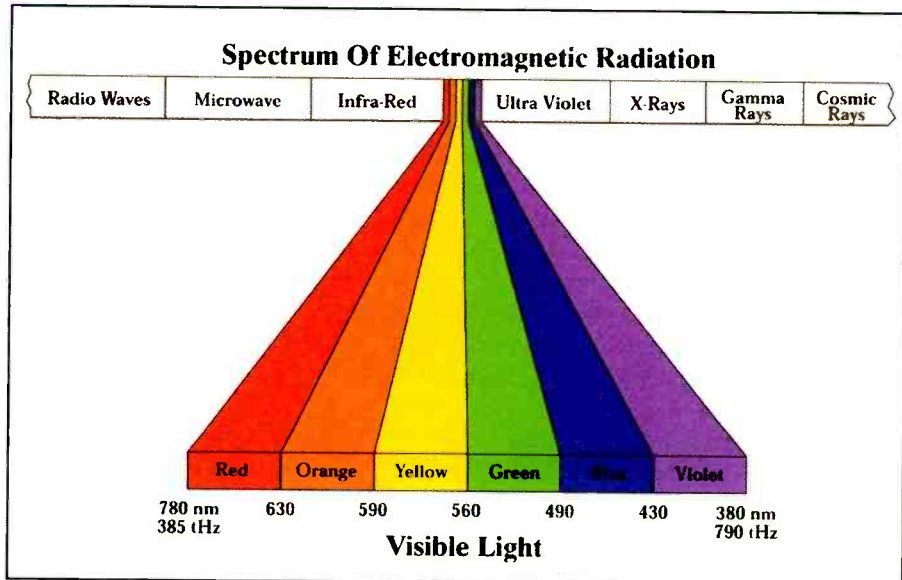

Figure 1. The high frequency visible light range, or spectrum, lies between 400 teraHertz and 750 teraHertz. Visible light is usually specified by wavelength rather than frequency. Each different wavelength of light energy (if seen alone) is perceived as a different color.

frequency energy. Other electromagnetic energy at frequencies lower than light include radio waves, microwaves, and infrared heat waves, and at frequencies higher than light are ultraviolet, x-ray, gamma, and cosmic rays.

The high frequency visible light range (Figure 1.), or spectrum, of 400 teraHertz to 750 teraHertz is usually specified by wavelength rather than frequency. Each different wavelength of light energy (if seen alone) is perceived

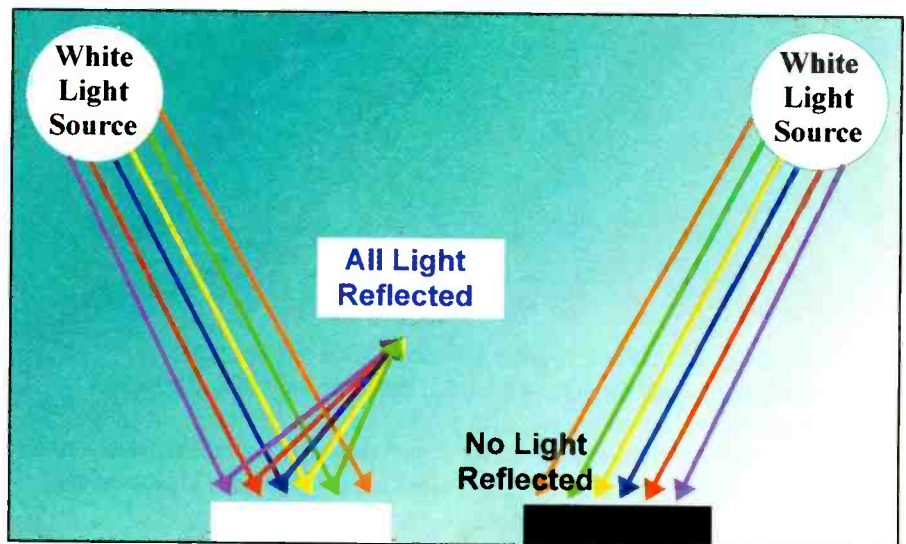

Figure 2. If the light energy from the sun is all equally reflected from some surface, the eye/brain sees the surface as white. If another surface absorbs all light energy and reflects none, the surface appears black to the human eye/brain.

Warner is an engineer for Sencore.

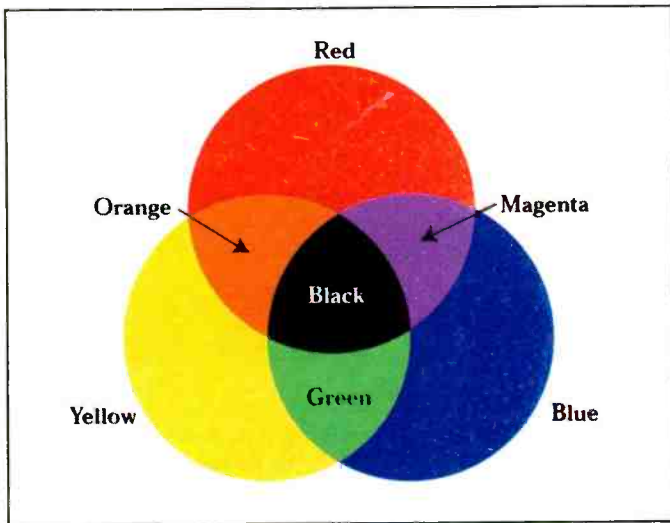

Figure 3. When paints, dyes, or pigments of two different colors are mixed, a third color results. The resulting material absorbs all the light energy that was absorbed by each of the two original materials.

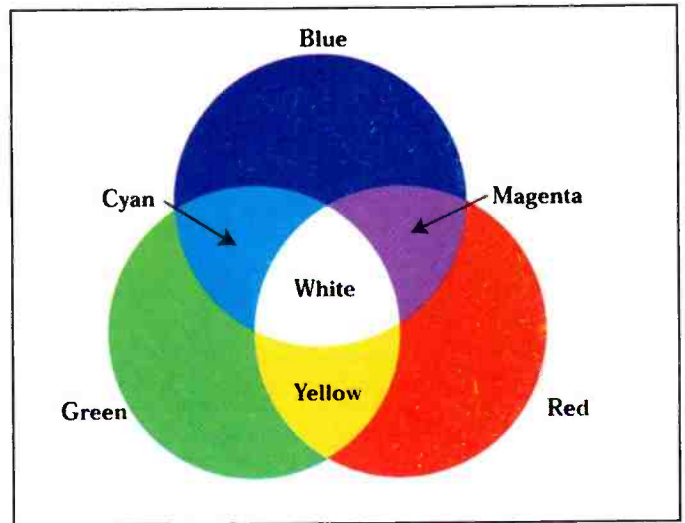

Figure 4. When light sources of two different colors are mixed, a third color results from the combination.



Figure 5. The human eye/brain system responds to three different characteristics of light: hue, saturation, and brightness.

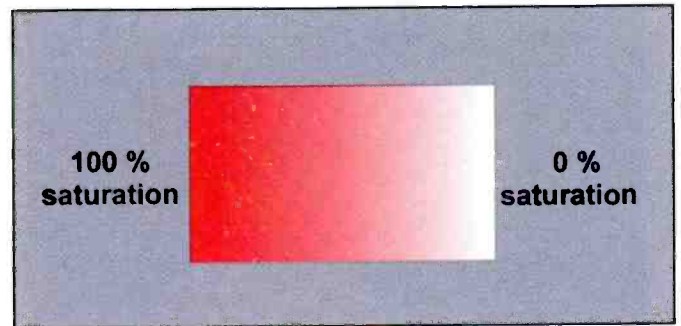

Figure 6. Saturation is the colorfulness of an area judged in proportion to its brightness, and is primarily the degree to which light energy is concentrated at a single wavelength.

by the human eye/brain as a different color. The lowest frequency visible light energy (extreme red) has a wavelength of about 750nanometers (billionths of a meter). The highest frequency visible light energy (extreme violet) has a wavelength of about 380nm. Some perceived colors, such as purple, do not correspond to any one wavelength of light, and are called non-spectral colors. These colors are the result of a mixture of various proportions of spectral colors.

If the light energy from the sun is all equally reflected from some surface, the eye/brain sees the surface as white. If another surface absorbs all light energy and reflects none, the surface appears black (Figure 2). If yet a third surface absorbs all light energy except that of one wavelength, which it reflects, the surface appears to the eye/brain as a particular color. If only long wavelength visible light energy is reflected, the surface appears some shade of red; short-

wavelength visible light appears some shade of violet.

Color mixing

If more than one wavelength is reflected, the eye/brain performs a mixing of all light energy present and perceives a single color which is a result of the mixture. Paints, dyes, or pigments appear a particular color because they absorb light energy of all other wavelengths. The color of a solid object is formed by the scattering or reflection of only those colors in the illuminating light source which are not absorbed. This is a subtractive process.

When paints, dyes, or pigments of two different colors are mixed, a third color results (Figure 3). The resulting material absorbs all the light energy that was absorbed by each of the two original materials. The resulting color mixture is always darker than either of the two

original colors since more light energy is being absorbed.

When viewing a mixture of light sources directly, however, the eye simply sees a summation of all the light energy present in the individual light sources. This is an additive process. When light sources of two different colors are mixed, a third color results (Figure 4). The resulting color is always brighter than either of the two original colors since more light energy is present in the light mixture.

Since the light sources mix by an additive process rather than a subtractive process, the resulting color is different than when mixing paints of the same colors. The figure illustrates the additive mixing process that results when mixing lights.

When mixing either paints or lights, a set of three primary colors is often chosen, which are then mixed in various combinations to reproduce the range of



Figure 7. As more light of all wavelengths is added to light of a single wavelength (a single color), eventually the color reaches zero saturation, which is white light.

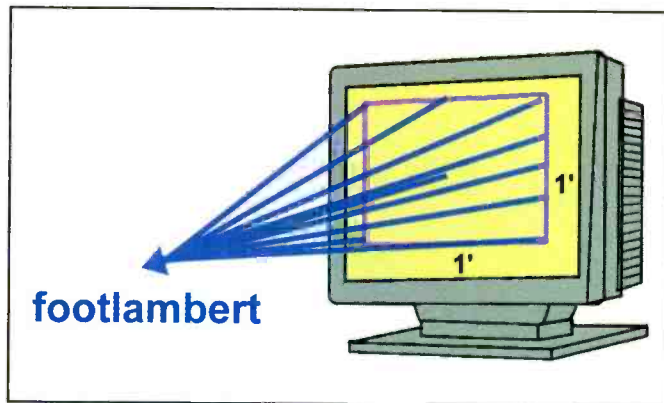

Figure 8. The footlambert is the U.S. measurement unit of luminance. It specifies the amount of light energy, per square foot, emitted from a light source (such as a CRT) or reflected from a lighted surface.

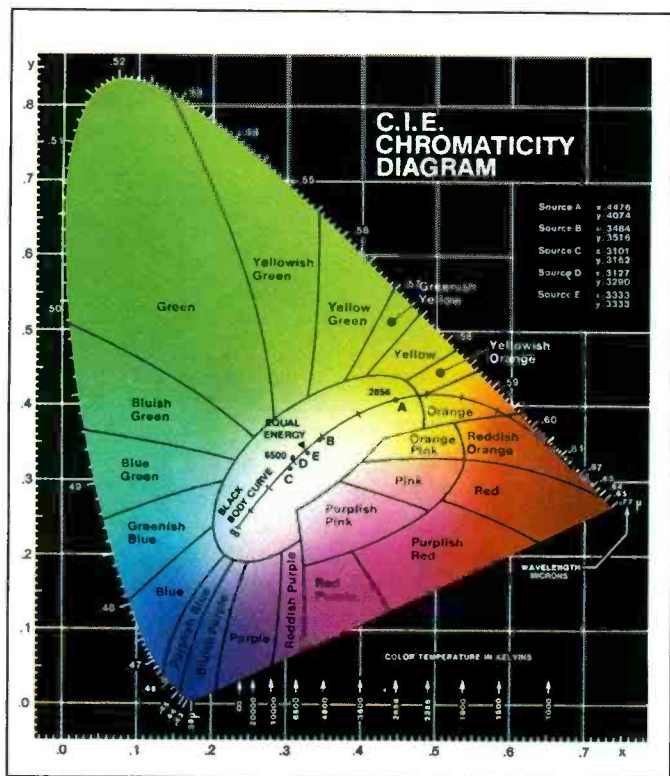

Figure 9. A chromaticity diagram graphically depicts the relationship between hue (light wavelengths) and purity and allows the specification of individual colors with an x-y grid system.

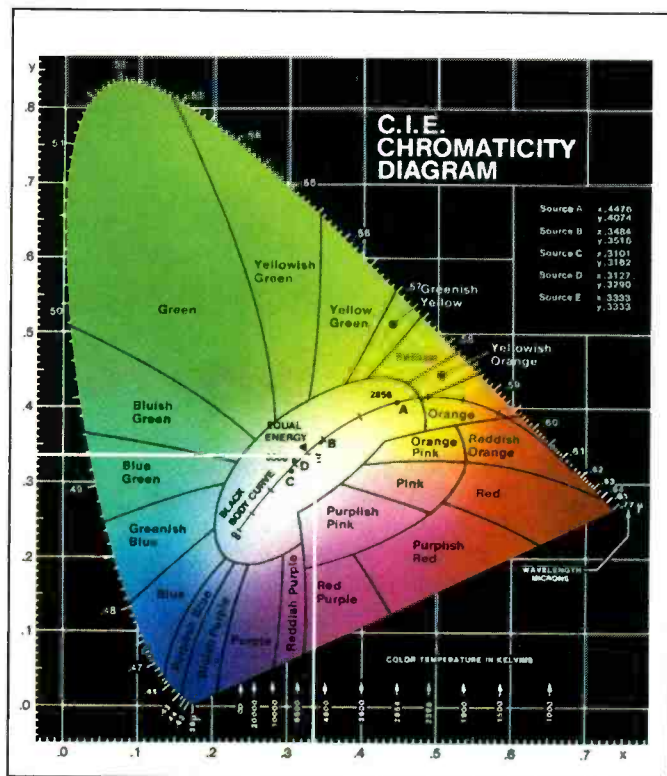

Figure 10. The C.I.E. diagram provides a grid coordinate system to specify a precise measurement of any spectral color or color combination. A C.I.E. coordinate of $x=0.333$ and $y=0.333$ specifies the white light perception produced by equal light energy of all wavelengths.

desired colors. Primary colors are simply a set of colors (usually three) chosen such that none of them can be duplicated by any combination of the other two.

There are infinite sets of primary colors. The choice of primary colors determines the range of mixed colors able to be reproduced. For mixing paints, pigments, and dyes, the primary colors of red, yellow, and blue are often chosen,

although printers usually use cyan, yellow, and magenta.

For mixing lights, the primary colors of red, green, and blue are usually chosen because they correspond most closely to the response of the eye and provide the greatest range of color matches.

Color perception

The human eye/brain combination responds to three different characteris-

tics of emitted or reflected light energy (Figure 5). These three human sight characteristics are:

- hue,
- saturation, and
- brightness.

Hue is the perceived color of visible light energy, expressed as violet, blue, green, yellow, orange, red, etc. This hue may be a result of a single wavelength of

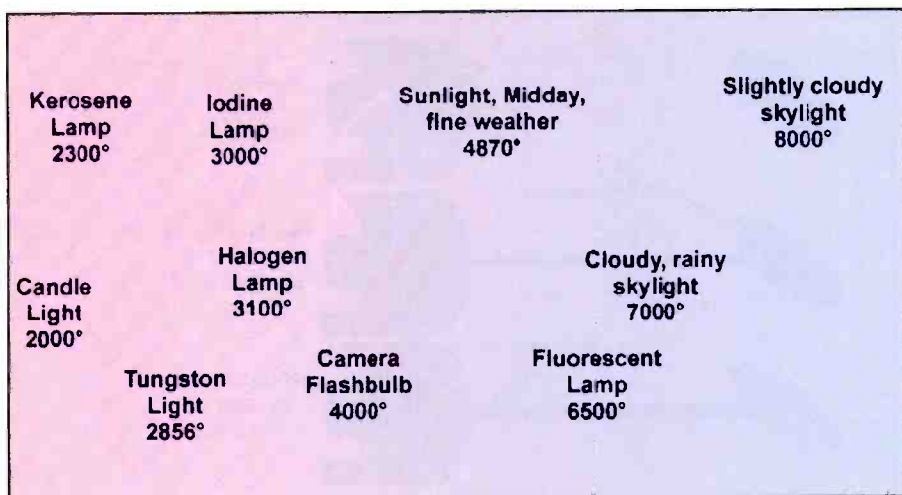

Figure 11. Common light sources range from a color temperature of around 2500° K (more red) to over 9000° K (more blue). Equal energy white is approximately 6000° K.

Color Temperature (° Kelvin)	CIE Chromaticity Coordinates	
	x	y
Illuminant A (tung. - 2856°)	0.448	0.408
3000°	0.437	0.404
4000°	0.380	0.377
Illuminant B (sun)	0.349	0.352
5000°	0.345	0.352
Illuminant D5500	0.332	0.348
Equal Energy White	0.333	0.333
6000°	0.322	0.332
Illuminant D6500	0.313	0.329
Illuminant C (NTSC - 6700°)	0.310	0.316
7000°	0.306	0.317
Illuminant D7500	0.299	0.315
8000°	0.295	0.305
9000°	0.287	0.296
9300°	0.283	0.298
10,000°	0.281	0.288
20,000°	0.257	0.258
40,000°	0.247	0.245

Figure 12. Color temperatures of some common light sources and white reference standards. Incandescent light contains more red light, while fluorescent light or sunlight tends to be more blue. Any illuminated object reflects light of slightly different hues under each of these different lighting conditions.

light energy or the dominant wavelength of multiple wavelengths of light energy. The term color is often interchanged for hue. Since white light is a combination of all colors of light, and has no dominant wavelength, it has no hue.

Saturation is the colorfulness of an area judged in proportion to its brightness, and is primarily the degree to which light energy is concentrated at a single wavelength (Figure 6). Light energy of a single wavelength, appearing to the eye/brain as the color red for example, is at maximum saturation.

Light of equal energy at all wavelengths appears to the eye/brain as white and is at zero saturation. As some white light is added to pure red light, the red desaturates somewhat to a pastel pink. As more light is added at wavelengths other than red, eventually the color

reaches zero saturation, which is white light (Figure 7).

Brightness is the visual sensation in which an area appears to emit more or less light. Brightness is a characteristic of any light source, while hue and saturation are characteristics only of light sources that are not balanced white light.

White and shades of gray have different brightness levels, but have no hue and have zero saturation.

Light measurement

To specify precise color measurements of light energy from a source or reflecting surface requires that a set of light measurement units be defined. Many light measurement units have been developed for this purpose, but only a few are important in video system calibration and servicing.

The footlambert is the U.S. measurement unit of luminance (Figure 8). It specifies the amount of light energy, per square foot, emitted from a light source (such as a CRT) or reflected from a lighted surface.

Luminance is a light measurement term closely related to the human sight characteristic of brightness. The luminance of monitor CRTs, at full brightness and contrast settings, is typically in the range of 30 to 100 footlamberts.

A more familiar light measurement unit, the footcandle, is very similar to the footlambert. The footcandle is the U.S. measurement unit of illuminance. It specifies the amount of light energy, per square foot, falling on a lighted surface.

The chromaticity diagram

The specification of light measurements relating to hue and saturation has proven a bit more complex. In 1931, an international commission on illumination (the C.I.E.) developed a chromaticity diagram which graphically depicts the relationship between hue (light wavelengths) and purity and allows the specification of individual colors with an x-y grid system (Figure 9).

This C.I.E. Chromaticity Diagram (also known later as the Kelly Chart for improvements Mr. Kelly made to it) also shows the effect of mixing two or more colored lights together to produce another color of light, or white.

The tongue-shaped diagram shows the pure spectral colors around the curved border of the tongue, plus the results of mixing any of these spectral colors at the base and center of the tongue.

If any two color points are chosen on the diagram, a line drawn between the points passes through the range of colors produced by mixing various proportions of the two original colors. Colors shown around the outside of the diagram are highly saturated, progressing to zero saturation white at the diagram's center.

Note that the perception of purple and other colors at the base of the diagram cannot be produced by a single wavelength, but require a mixture of short and long wavelengths.

If any three color points are chosen, the area included by the connecting triangle represents the range of colors able to be produced by mixing the three chosen colors. The three points are the col-

ors of the CRT phosphors primaries specified by the NTSC for the U.S. television system (but seldom precisely the actual phosphor colors used in TVs). The connecting triangle includes the full range of colors able to be produced by a CRT using these color phosphors.

Any three colors not lying on a straight line with one another are a set of color primaries.

The C.I.E. diagram provides a grid coordinate system to specify a precise measurement of any spectral color or color combination. A C.I.E. coordinate of $x=0.333$ and $y=0.333$, for example, specifies the white light perception produced by equal light energy of all wavelengths (Figure 10).

The color of any point immediately surrounding the equal energy white point would, if seen by itself, be perceived as white. This range of nearly white colors surrounding the equal energy white point is known as the "near white" region of the C.I.E. diagram.

Color temperature

We sometimes use yet another method

ES&T Calendar

ETA Annual Membership Meeting
May 5-6, 2000
ETA Headquarters
604 N. Jackson
Greencastle, IN 46135, and
The Walden Inn
Greencastle, IN
ETA: 765-653-8262

NESDA 50th/ISCET 30th/NIAS 8th
Annual National Professional Service
Convention and Professional Service Trade
Show
August 7-12, 2000
John Ascuaga's Nugget Hotel
Sparks (Reno) NV

NESDA
2708 W. Berry
Fort Worth, TX 76109-2356

CEDIA Expo
September 6-10, 2000
Indianapolis Convention Center
Indianapolis, IN

Custom Electronics Design and Installation
Association (CEDIA)
9202 N. Meridian #200
Indianapolis, IN 46260-1810
800-669-5329
www.cedia.org

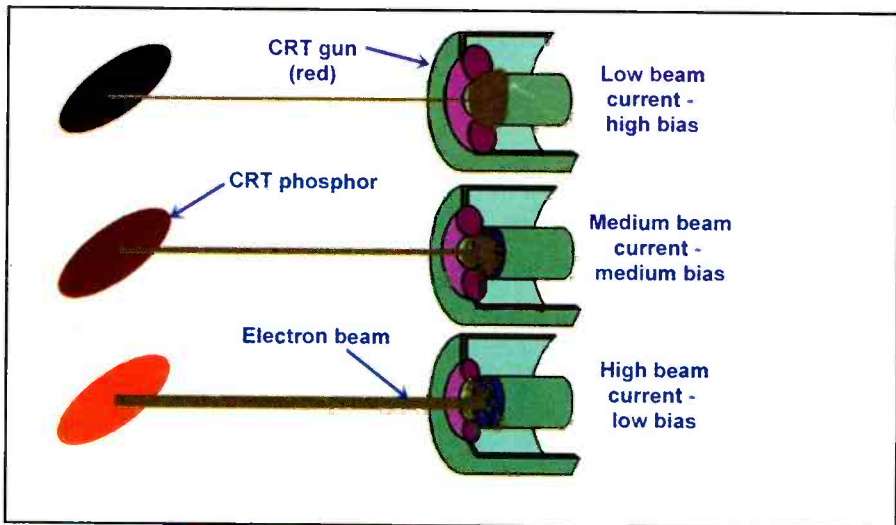

Figure 13. In order for a CRT to produce an image on the screen, the intensity of the electron beam from the cathode to the phosphor screen must be made to vary. Changing the bias voltage in step with the video image to be produced varies the beam current. White and bright colors require high beam current, while grays and dark colors require a small beam current.

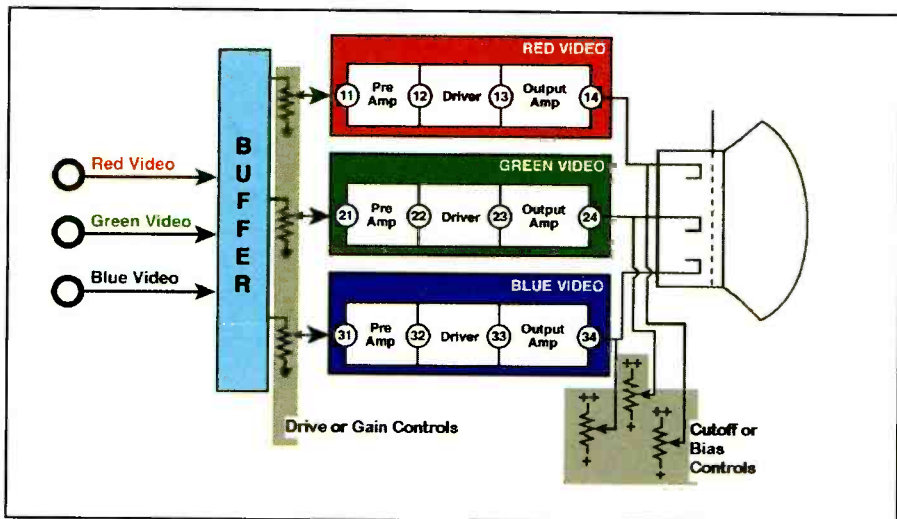

Figure 14. Video display circuits include two sets of adjustments to produce neutral white and proper grays and colors over the entire brightness range.

of measurement known as color temperature, to specify the differences in the hue of near-white light sources. The unit of measurement for color temperature is degrees Kelvin ($^{\circ}\text{Kelvin} = ^{\circ}\text{Celsius} + 273$). The reference for this measurement is the color of light produced when carbon is burned at different temperatures.

Common light sources range from a color temperature of around 2500°K (more red) to over 9000°K (more blue) (Figure 11). Equal energy white is approximately 6000°K .

An easy comparison to think of for color temperature is a black iron bar heated to different temperatures in a blacksmith's forge. As the bar begins heating, it glows an orangish-red, as it

begins to reach hotter temperatures the bar becomes a bluish-white.

See Figure 12 for color temperatures of some common light sources and white reference standards. Incandescent light contains more red light, while fluorescent light or sunlight tends to be more blue. Any object reflects light of slightly different hues under each of these different lighting conditions.

Understanding how a CRT produces an image on the screen

In order for a CRT to produce an image on the screen, the intensity of the electron beam from the cathode to the phosphor screen must be made to vary.

Changing the bias voltage in step with the video image to be produced varies the beam current. White and bright colors require high electron beam current, while grays and dark colors require a small electron beam current.

A video signal containing voltage variations that correspond to the picture is applied to the monitor. The video signal controls the three separate CRT electron guns. To produce various shades of gray, all three guns are turned equally more on or more off.

To produce color, the three video signals change differently from each other. One or two guns are turned on more and the other gun(s) are turned more off.

Before being applied to the CRT, the signal is amplified by the monitor's video display circuits. Depending on the type of monitor, video input signals are typically 1V_{pp} or 5V_{pp}. A signal of 100V_{pp} or 200V_{pp} is needed to drive the electron gun of most CRTs.

Video display adjustments

Video display circuits include two sets of adjustments to produce neutral white and proper grays and colors over the entire brightness range (Figure 13). The first set of adjustments are called the CRT cutoff or bias controls. They control the dc bias applied to the CRT guns to obtain color balance (neutral gray) at low luminance level just above cutoff.

The second set of adjustments is called the CRT drive or gain controls. They control the maximum amplitude of the video signal sent to each CRT electron gun to obtain balance (neutral white) at a high luminance level near maximum electron gun conduction.

Adjusting the bias and drive controls in a video display is called the White Balance or Gray Scale adjustment.

Understanding the operation of a color analyzer

A color analyzer measures the x and y chromaticity and Y luminance or brightness parameters required for making the important computer monitor color and brightness adjustments (Figure 15). A color analyzer makes the x and y and luminance parameter measurements in the following way:

The red, green, and blue light emitted

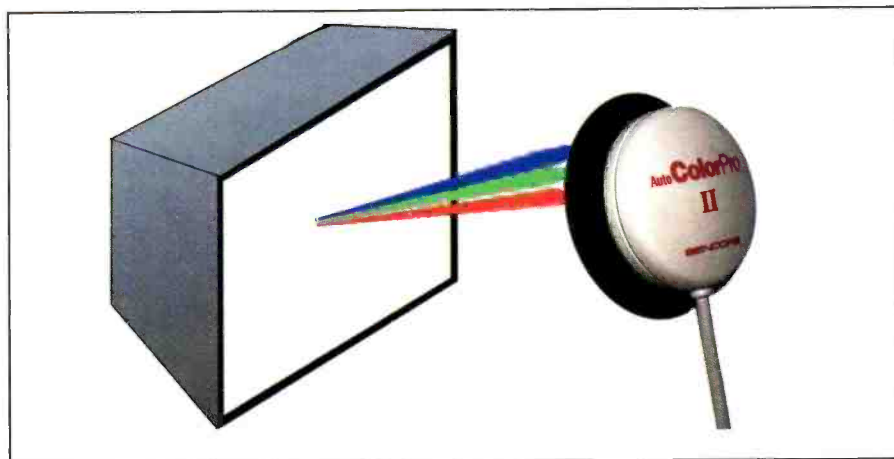

Figure 15. A color analyzer measures the x and y chromaticity and Y luminance or brightness parameters required for making computer monitor color and brightness adjustments.

by the CRT phosphors enters the receptor area of the measuring probe. The light passes through the spectral-response correction filters and strikes the light sensors. Each light sensor outputs a voltage that is proportional to the intensity of the light striking it. These

voltages correspond to both the intensity and color temperature of the light applied to the probe.

Analog-to-digital converters change the voltages into digital values that are displayed in either a graphical or a numerical format. ■

Introducing Two NEW Troubleshooting Books from Newnes!

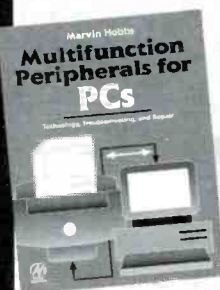

Multifunction Peripherals for PCs Technology, Troubleshooting and Repair

Marvin Hobbs

Multifunction devices combine the essentials of a fax machine, printer, scanner, and copier into one peripheral for small and home offices. *Multifunction Peripherals for PCs* teaches you how multifunction peripherals work in theory and in practice with lots of hands-on examples and important troubleshooting and repair tips you don't want to miss.

December 1999 * pa * 232pp. * 0-7506-7125-4 * \$32.95

Audio & Hi-Fi Troubleshooting and Repair

Nick Beer

Based on hard-won experience on the bench and in the field, this book is the next best thing to having an experienced engineer sitting alongside the bench: advising, guiding, cautioning, and pointing the reader in the right direction. This new edition brings complete information on fault diagnosis, repair and testing of all classes of home audio equipment: receivers, amplifiers, recorders, and playback machines.

May 2000 * pa * 256pp. * 0-7506-7242-0 * \$39.95

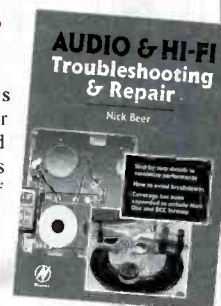

Ordering Information:

Write: Newnes, 225 Wildwood Ave., Woburn, MA 01801

Call: 1-800-366-2665 or 781-904-2500

Fax: 1-800-446-6520 or 781-933-6333

E-mail: crders@bhusa.com



Visit Our Website: www.newnespress.com

Promo Code
NAH

Circle (66) on Reply Card

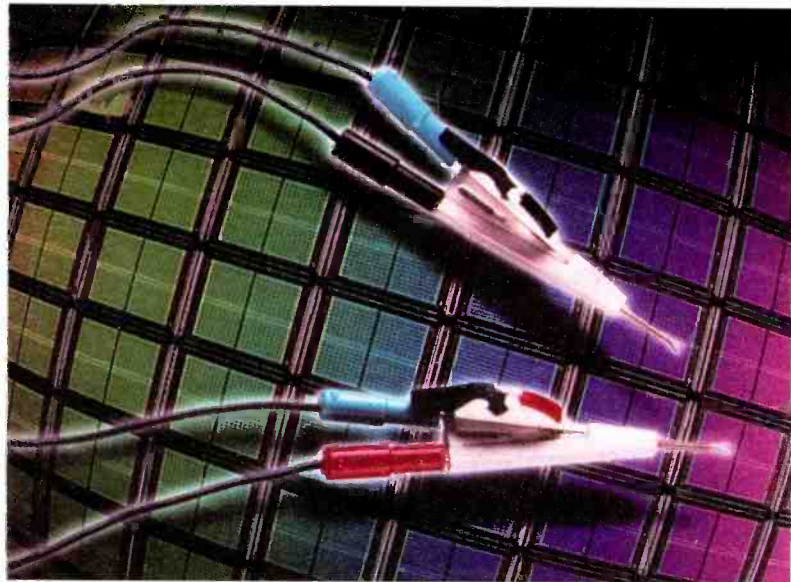

Try to imagine a carpenter building a house without a saw, a hammer, measuring equipment, a level, or any of the other tools that are the symbols of his trade. Or do you remember the last time you went into the doctor's office for a visit? Here's a profession whose practice is mainly carried out in the brain of the professional, but he, and his assistants require a lot of tools: a stethoscope, thermometer, scale, blood pressure measuring device, x-ray equipment, and more.

Every type of work requires tools. Consumer electronics is no exception. In fact, sometimes when we think of the job, it's easy to forget how many tools are required. Moreover, there are many other tools that may not be essential, but under the right circumstances, can make the work more efficient: so much so that they eventually pay for themselves in time saved.

Just take a look at the array of tools, including test equipment, that a technician uses every day: screwdrivers, wrenches, pliers, wire cutters, wire strippers, soldering iron, vacuum solder remover, magnifying glass, task lighting, jigs, fixtures, vises, snap ring pliers. The right tool, and a quality tool at that, applied at the right time can make the work go smoothly. If the needed tool isn't at hand, or if the tool is not of the required quality, the job might take more time than it should, or the technician might even cause damage to the very product he's charged with fixing.

Beyond the basic tools, there are the tools that can automate and speed work so that it can be done in volume. Some of those tools that come to mind are the power screwdriver. A tool such as this can zip fasteners off when disassembling and back on when reassembling, saving considerable time. And they save more than time: repeatedly twisting screws, nuts, and bolts on and off can cause fatigue, and even injury to the hand and wrist. Power drivers can alleviate those problems.

Another tool in the category of time saver is the soldering station. One of these can be left idling all day, ready to desolder a joint at any moment, and if equipped with an integral vacuum desoldering system and fume removal system, one of these units can whisk away the solder as soon as it melts it, and remove noxious fumes at the same time.

The computer as tool

The definition of the term "tool" as applies to consumer electronics is constantly changing. A very useful tool these days is the personal computer. That may sound like a strange statement, but it is true. In fact, the article "Camcorder servicing," in this issue, describes the use of the computer in servicing a camcorder.

Some consumer electronics products today, camcorders, and TVs contain a great deal of computer-like circuitry: a microprocessor is used to control some of the functions of the product, and data stored in EEPROM (electrically erasable programmable read-only memory) directs the processor in carrying out those functions. The ROM data performs a function similar to the function of adjustment controls in earlier products.

As the product ages, or otherwise ceases to function properly because of failure of adjustments, the technician can connect the computer to the product, check the operation of the unit, and change the EEPROM data, restoring the unit to proper operation. In this case, the computer has served the function of both a piece of test equipment in observing the product's operation, and the function of a tool that is the modern equivalent of a screwdriver or alignment tool.

Selecting a vendor

You can buy most tools just about anywhere. Every hardware store, department store, or discount store has a tool department where you could probably obtain many of your tools. But then the tool needs of a consumer electronics servicing technician are pretty demanding and many of the tools needed to service a TV, VCR, camcorder, or personal computer are special-purpose tools. It might, therefore, be more effective to select tools from vendors who know the special needs of the technician.

The showcase

This Tool and Toolcase Showcase is designed to provide readers with a little more information than is ordinarily available about tool vendors. Each advertiser in this showcase has been given an additional amount of space to tell readers about their company in the hope that it will help in the process of determining who is most likely to carry the kinds of tools most targeted to consumer electronics service.

As you read the descriptions of these companies, written in their own words, you might want to keep these questions in mind:

- How long have they been in business?
- How often are they able to fill orders from stock?
- What payment options do they offer: open order account, credit card?
- How soon after receipt of an order do they ship?
- Do they add a shipping surcharge?
- Do they have a toll free number?
- What ordering options do they offer?
- What is their return policy?
- Do they offer a warranty?
- Is there a minimum order amount?
- What shipping options do they offer?
- What special services do they offer?

Jensen Tools Inc.

7815 South 46th Street
 Phoenix, AZ 85044
 Phone: 800-426-1194
 Fax: 800-366-9662
 E-mail: jensen@stanleyworks.com
 Website: <http://www.jensentools.com>



Jensen Tools, a division of Stanley Works, has led the industry in providing tool kits for the professional field service technician since 1954. The JTK® trademark signifies an original Jensen design and is the symbol that sets us apart from the rest.

Jensen offers a wide range of original JTK® tool kit designs. Variations to our standard designs permit customers to choose from over 160 ready-to-ship tool kits. Jensen's JTK® tool kits are available in a number of choices including general electronics, electro-mechanical, industrial mechanical, biomedical, telecom, network/PC and many more. Any JTK® tool

kit can easily be modified to add or delete specific items as needed. Jensen's line of Vantage™ kits offers quality tools at economy prices.

Jensen's "Create-A-Kit"™ is a unique feature that allows you to select from 7 case styles and 17 different pallet configurations to quickly design your own custom kit in two easy steps. For more individual needs, the Jensen Kit Team will actively work with you to design and build tool kits for requirements such as pallet layout design, custom foam cutouts, tool case fabrication and other unique specifications.

Great kits start with great cases, and

Jensen offers the industry's best. Cases are available in polyethylene, aluminum or soft-sided Cordura® Plus in a variety of sizes and styles. Extra-rugged Rota-Tough™ cases with impact resistant comers and "Tote" cases with heavy-duty wheels and telescoping friction-controlled handles are also available. Jensen's Quick Clip design makes pallet removal fast and easy.

Jensen provides a 30 Day Unconditional Guarantee on all tool kits, with a Lifetime Guarantee on Jensen brand hand tools. Other customer benefits include free technical support, a 24 hour/7 day FaxBack® Service for technical documents, secure online ordering, and free same day shipping on many orders.

Jensen recently introduced the JTM line of handheld meters and the JTS line of telephone test sets. Look for these items — plus hand and power tools, electrical and electronic test equipment and many other products from major manufacturers — in the latest edition of the Jensen catalog. For your FREE copy, call us at 800-426-1194, Department 082 or visit us online at www.jensentools.com. ■



What's New at Jensen?

Everything you need to install, maintain & repair electronic equipment, including:

Jensen original tool kits, specialty tools, test equipment, workstations and accessories, soldering stations, wire & cable, and more.

- ✓ 100% Satisfaction Guaranteed
- ✓ Lifetime Guarantee on Jensen Brand Hand Tools
- ✓ Free Same Day Shipping
- ✓ Free Technical Support
- ✓ 24 hour/7 day FaxBack® Service
- ✓ Secure Online Ordering



Check out the new Jensen brand handheld meters and telecom test equipment

JENSEN TOOLS

7815 S. 46th Street, Phoenix, AZ 85044
 Tel: 800-426-1194 Fax: 800-366-9662
 E-Mail: jensen@stanleyworks.com
 Online: www.jensentools.com

Aven Tools, Inc.

4595 Platt Road

Ann Arbor, MI 48108

Phone: 800-624-8170

Fax: 734-973-0097

Website: www.aventools.com

E-mail: info@aventools.com

Since 1983, Aven Tools has been a provider of precision hand tools to the electronics industry for the assembly, repair, and service of electronic equipment. The first Aven product introduced to the marketplace was its precision tweezers, and since then we have grown to offer over 750 different products.

Aven has continued to build a broad selection of products to keep up with the ever-increasing demand of the industry. A digital soldering station,

inspection microscopes, a video inspection system, and completely assembled tools kits are some of the latest additions to our ever-increasing product line.

Aven now offers 35 different tool kits, including datacom (installer, coax termination, twisted pair, etc.), field service, and networking. Our goal is to make kits that meet the user's needs, while making them durable and affordable. From rugged hard shell cases with built in hand

carts to soft sided cordura nylon cases, each one features premier ergonomic screwdrivers, pliers, and cutters. All of our hand tools come with a lifetime warranty.

Looking to the future, Aven is gearing up to become your "One Stop Shop" for electronics tools and related equipment. Aven is planning a new e-commerce site to be in operation in mid-July 2000. A new catalog for 2001 is currently in the works.

WE MAKE YOU LOOK PROFESSIONAL!!

Aven has a tool kit for every application.

Featuring 35 different kits to choose from, all of Aven's tool kits feature our premier line of ergonomically designed screwdrivers, pliers, and cutters, and have large storage pockets for spares and additional tools.

From datacom to field service, we have a kit that's right for you, priced at much less than you would expect for a kit of this quality.

Call us today for a free tool kit brochure at

800-624-8170.

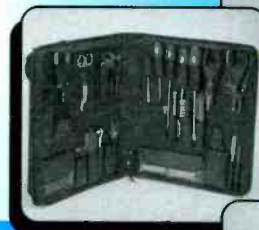

DELIVERING PERFORMANCE WITH VALUE

Aven Tools Inc.

4595 Platt Road, Ann Arbor, MI 48108

Ph: 800-624-8170 • Fax: 734-973-0097

www.aventools.com • info@aventools.com

Circle (49) on Reply Card

Books

CSS Study Guide, from The Electronics Technicians Association, 116 pages, \$30.00

The Electronics Technicians Association, International, Inc., has published the second edition of the *CSS Study Guide for Customer Service Specialists*.

The 116-page book contains 19 chapters of instruction, rules, policies, and techniques that have proven to be needed by workers who handle customers, as service technicians, installers, repairers, help-desk workers, receptionists, and sales people.

While ETA's Certifications program for customer service specialists was originally intended for electronics technicians, it quickly was reconfigured to broaden its scope to cover virtually all areas of work that require interfacing with the public.

The CSS program is now offered as a stand-alone short course at some technical schools and as a segment added onto many computer and electronics technical courses. This CSS study guide provides a virtual course outline and prepares students to pass the CSS Certifications Examination. It contains over 170 practice CSS Quiz questions.

Electronic Technicians Association, 604 North Jackson, Greencastle, IN 46135,
Phone: 800-288-3824, Fax: 765-653-4287

Digital Television Fundamentals: Design and Installation of Video and Audio Systems, by Michael Robin and Michel Poulin, 571 pages, hardcover, \$60.00

Television and broadcast engineers grappling with the change from analog to digital television must be thoroughly versed in both sides of the equation. This engineering-level guide provides that understanding. Chapters on data multiplexing, compression, signal processing, and multimedia clarify the complexities of digital television in terms that digital novices will readily grasp. Engineers will discover how to assure equipment compatibility in analog, digital, or mixed systems — meet relevant standards requirements — and measure performance in audio and video equipment. They'll also gain insights into JPEG and MPEG compression schemes.

McGraw-Hill, 1221 Avenue of the Americas, New York, NY 10020,
Phone: 800-352-3566

SMD Electronic Projects, by Homer Davidson, 336 pages, \$29.95

This book by renowned author Homer Davidson brings you 30 electronic projects, all utilizing surface-mounted devices. A fairly new technology, these projects are built with readily available components.

SMD components have opened up a brand-new area of electronics project construction. These tiny components are now available and listed in many of the electronics mail-order catalogs for the electronics hobbyist. *SMD Electronics Projects* includes everything you need to know to build 30 surface-mounted electronics projects. Surface-mounted devices are rel-

atively new to the electronic builder, but are essential components in various consumer electronics products including TVs, camcorders, stereo receivers, compact disc players, VCRs, and cassette players. Surface-mounted parts operate on low voltages and mount directly on the PC wiring. A parts list, schematic, wiring hookup, board layout, photos and drawings help to illustrate each projects. Troubleshooting procedures are given at the end of each project.

Projects include an Earphone Radio, Xtal Receiver, Shortwave Receiver, IC Radio, Shortwave Converter, FM Radio, Active Antenna, RF Amplifier, Sideband Adapter, Audio Amp, Xtal Earphones, FM Baby Monitor, Code Oscillator, LED Flasher, Melody Doorbell, Electronic Timer, Flashing Pin, Touch Alarm, Continuity Tester, Signal Injector, Audio Generator, Pink Noise Injector, Cable Checker, Xtal Checker, Laser Disk Tester, Injector-Audio Tester, and various recorders.

PROMPT Publications, 2647 Waterfront Parkway, East Drive, Indianapolis, IN
46213-2041

The Benchtop Electronics Handbook, by Victor Veley, 800 pages, hardcover, \$69.95

The publisher says, "find the Answer Faster in the Pro's #1 Handbook. When you have a question on digital principles, solid-state circuits, satellite earthstation transmitters, or any other aspect of today's electronics, turn to this unique reference. Your answer is at hand." A sourcebook used by electronics and communications professionals, this handbook takes you directly to the information you seek. You get: 260 topic chapters on today's electronics; Reader-friendly explanations; Mathematical derivations; Relevant equations for each topic; Examples showing how to apply the math; Sample projects you can make in your lab; Practice problems, with answers supplied. Written for electronics and communications professionals, students, and science-curious readers who want to master the technologies that power and shape today and tomorrow's world, this popular and unique sourcebook is the best benchtop reference in electronics. It has the answers and applications you want in: Alternating Current, Direct Current, Solid-State Circuits, Tube Circuits, Communications, Microwave, Applied Mathematics for Electronics, Digital Principles.

Contents

- Part I: DC Principles.
- Part II: AC Principles.
- Part III: Solid State Devices and Their Associated Circuits.
- Part IV: Tubes and Their Associated Circuits.
- Part V: Principles of Radio Communications.
- Part VI: Introductory Mathematics for Electronics.
- Part VII: Intermediate Mathematics for Electronics.
- Part VIII: Digital Principles.
- Part IC: Satellite Communications.
- Part X: Fiber-Optic Communications.

Prentice-Hall, 800-352-3566

Camcorder service

by the ES&T Staff

As digital technology and associated component fabrication techniques have become more sophisticated and reliable, it has become increasingly possible to incorporate computer controls into consumer products: cars, appliances, and consumer electronics products such as TV, VCRs, and camcorders. Computer control has several advantages over other kinds of control:

- computer control is precise and repeatable,
- digital bits in a ROM replace controls that are imprecise and can become noisy,
- computer control is inexpensive,
- operation can be altered by changing the operating software,
- the computer-controlled product can be diagnosed and sometimes repaired by connecting a computer to an external port on the product, without a need for the technician to take the case off.

One example of a product that has been made simpler to service through its computer control/service interface is the camcorder. The following description of a computer diagnosis of a

camcorder was adapted from Thomson Consumer Electronics service information.

Using a computer for diagnosis

Figure 1 is a typical connection for the diagnosis and adjustment of a camcorder equipped with a computer aided diagnosis system. To use a system such as this, a technician needs the following five items;

1. A camcorder that is compatible with computer diagnosis,
2. A computer interface cable for that camcorder,
3. A data disk for that model of camcorder,
4. A computer with a VGA display and a 486SX or better processor running the appropriate operating system,
5. An infinity adjustment lens.

The use of the light box shown is optional.

Once the technician has the equipment and software connected and running correctly, a menu with instructions and a list of items that can be checked and adjusted will be displayed on the computer screen. The basic sections displayed are; the VCR, Camera, Lens and the Emergency Data section. Also

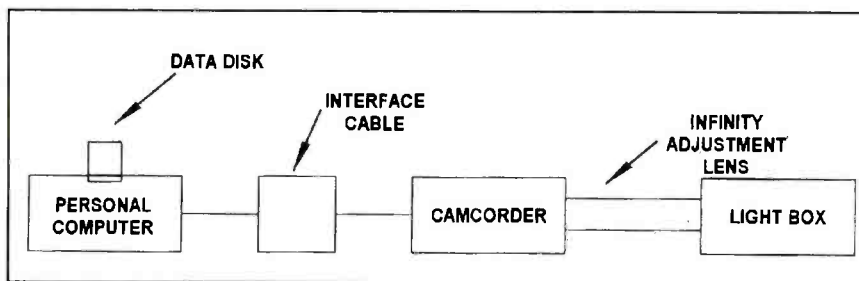
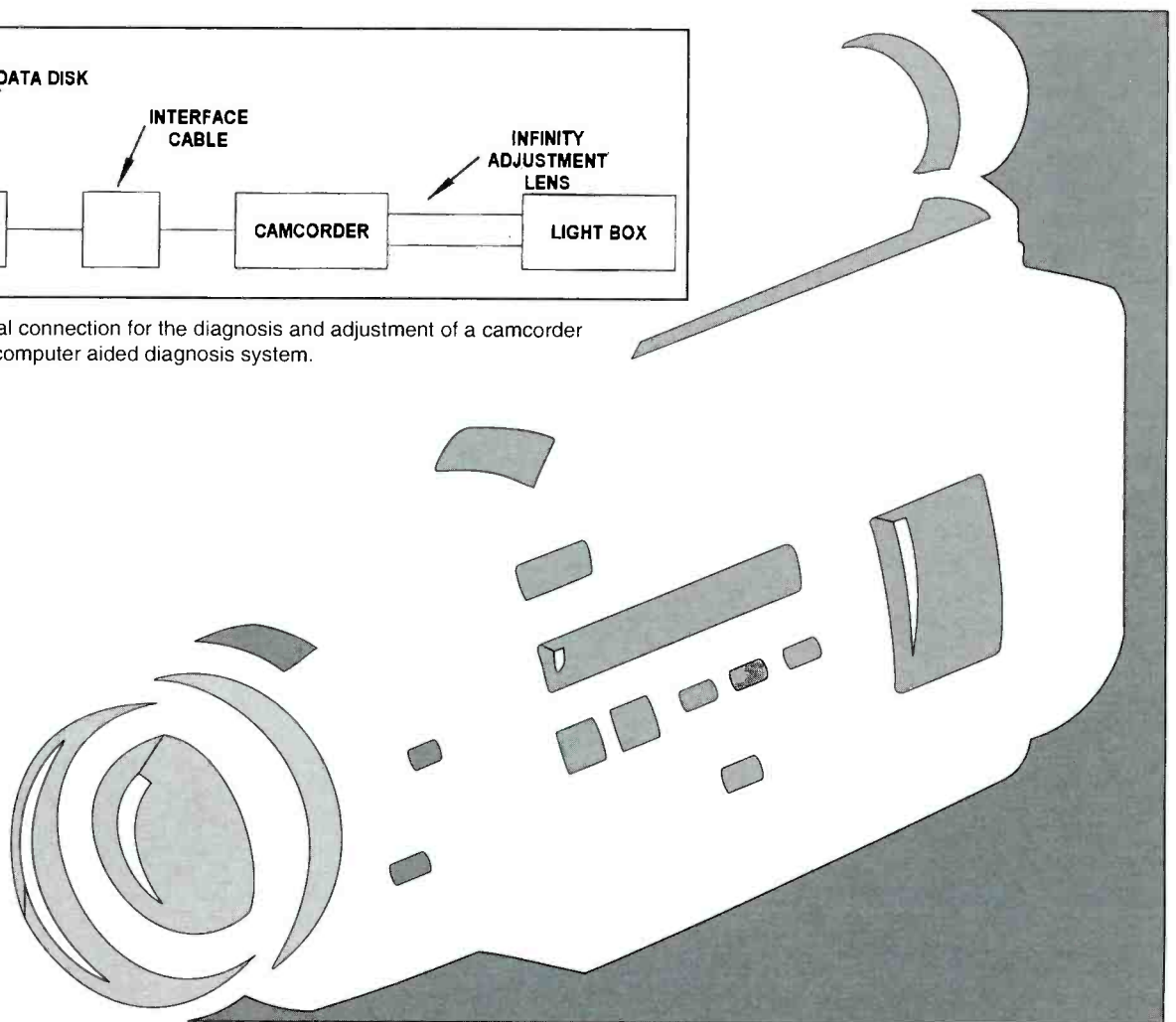

Figure 1. A typical connection for the diagnosis and adjustment of a camcorder equipped with a computer aided diagnosis system.



available for display are the actual contents of the EEPROM.

The manufacturer suggests that the technician make a backup copy of the camcorder's EEPROM data in case the data becomes corrupted during testing. The procedure for backing-up the EEPROM data is contained in the software for the model under test. The manufacturer suggests using the last eight digits of the serial number for the file name, to allow easy tracking of the repair.

With the camcorder and computer running, the technician has access to various sections of the camcorder. The actual items available will vary by model. A sample of some of the adjustment and areas that can be tested are listed below.

- Zoom
- Auto Focus
- Iris
- AGC
- Cinema Mode
- Shutter
- Scene (Back-lit, portrait etc.)
- White Balance
- Carrier Balance
- Bust Level
- Burst Phase
- White Clip
- R-Y Gain
- B-Y Gain
- Emergency Data
- VCR Play Back
- Switching Point

These are just a few of the tests and adjustments that can be performed without removing the case from the camcorder.

Alignment and test

Alignments are automated for the most part. The technician simply starts the test and looks for the results on the screen or oscilloscope. This allows the technician to quickly check a camcorder for proper operation.

One good example of the benefit of computer aided diagnostics would be the case of a problem with the iris. Let's say a customer brings in their camcorder and complains that the picture is too bright and appears washed out. The front desk person writes up a invoice and places the camcorder with the units to be repaired. A few days later, a technician brings the camcorder out for service. He turns it on and it appears to be functioning correctly. Now what? The customer described the problem, but the technician can't duplicate it.

The service center has two choices;

1. return the unit as is to the customer, or
2. connect it to the computer via the interface for a thorough diagnosis.

Let's say the service center chooses to check out the camcorder by connecting it up to the computer. After set up, the technician runs the alignment portion of the test and all seems to be functioning normally. Then the software reaches the step for the iris adjustment.

The results of the first test are acceptable, then the message appears on the screen telling the technician that after the computer closes the iris to make the adjustment. The iris does not close. The technician moves the camcorder and the iris closes. The technician goes to the alignment menu and open the iris electrically and then attempts to close it. Again it stays open. A tap on the unit causes the iris to close.

In less than 5 minutes, the technician has diagnosed the problem. Initially, the technician had checked the camcorder's operation indoors under normal lighting. Under these conditions, the iris never had to close down. It remained wide open and the picture appeared normal. However if he had taken the unit outside, he would have seen an extremely bright picture. The customer had failed to mention this aspect of the problem.

Using the computer, the technician diagnosed the problem, ordered and replaced the defective iris and realigned it all in less than an hour. Not all units can be diagnosed and repaired this rapidly. But use of the computer as a diagnostic tool and not just an overpriced alignment tool, can make this type of diagnosis more efficient.

EEPROM

The data stored in the EEPROM can also be changed using this system. Each memory location is labeled as to its function as it is selected. Here's an example of what can be done using the computer and interface. Let's say that the service center receives a camcorder in for service with a complaint of weak or no video. The technician verifies the complaint then connects the camcorder to the computer.

The first step is to store the original EEPROM data so that if something goes wrong during the service procedure, the technician can restore the camcorder to its original condition. The next step is to locate the memory location that controls the iris. It is important to note the data stored in the iris location before changing it so it can be restored after troubleshooting is completed. Then the technician can change the data from full closed to full open or anywhere in between, simply by changing the data from 00 to FF.

As the data is changed, the picture should become lighter or darker as the iris is opened and closed. If no change is noted, reset the data for the iris to its original value and then go to the Y amplifier and perform the same test.

If a change is noted, the problem would be in the iris control circuit and the technician will need to open the camcorder and see if the voltage to the iris is changing. If the voltage changes but the iris does not move, change the iris motor. If the voltage does not change, troubleshoot the iris control circuit.

This is only a small example of what can be done with the aid of a computer. The procedure in the example can be applied to any circuit that has its value stored in the EEPROM. Remember that the data for each location should be noted before changing it. It must be set back to the original value once troubleshooting is completed.

Emergency data

Emergency data (failures that are monitored) is stored and is beneficial for rapid diagnoses. The emergency data is stored in non-volatile memory for the last three emergencies encountered. Use of this data, along with the customers complaint, will allow the technician to diagnose many intermittent problems without taking the case off.

Summary

This article has considered some of the benefits that can be realized by the use of the computer for day-to-day troubleshooting. From storing common failures by chassis to diagnosing defective products, the computer has become an important service tool. It is as essential today as a digital voltmeter or oscilloscope is to any well-equipped service center. ■

Service Tips Software

by the ES&T Staff

Consumer electronics servicing technicians are justifiably proud of the work they do. Actually, it's pretty amazing when you think about it, that an individual can place a complex electronics product of today on the bench, perform a few tests, replace a few components, and restore the product to proper operation.

Of course, the secret to the troubleshooting process is that there's really much more to it than described by just those few words. If a technician is to be successful in diagnosing and correcting a problem, the key is knowledge. Knowledge of how electronics components and circuits operate in general, knowledge of how the specific product is supposed to operate under normal conditions, and a general knowledge of how the unit operates, or, perhaps more correctly, doesn't operate, when some component has failed.

So where does this knowledge come from? Much of the knowledge a technician brings to the service process comes, of course, from his education. All those long hours in class, learning Ohm's Law, Kirchhoff's law, all those rules, like the left hand rule, the right hand rule. All of that learning in the classroom, combined with practical, hands-on, experience in the lab, measuring voltages and currents, provide the general background that helps a technician's thinking process when faced with a TV circuit that just doesn't work right.

Making notes

Being able to observe the nature of a fault in a product, scrutinize the schematic drawings and other service information, and compare that information with the basic knowledge learned in the classroom and lab, and come up with a proper diagnosis is the very heart and soul of troubleshooting. Unfortunately, if a technician had to take that approach to every problem he encountered, he probably wouldn't be very successful. It just takes a lot of time. And given the prices of

today's consumer electronics products, if a technician takes too much time to pinpoint the problem, it won't be possible to effect the repair economically.

Technicians know that most faults in consumer electronics products are predictable, repeatable, of this type: if an XYZ model TV is brought in with no picture and certain other symptoms, ninety percent of the time the problem is the horizontal output transistor. That means that once a technician has encountered one of these sets with that problem, the next time he sees one, the first thing he will do will be to check out the HOT. Ninety percent of the time that will solve the problem.

Unfortunately, the human memory being what it is, and given the number of different brands and models of many different products, it's easy to forget exactly what the problem/solution was on a particular product. Most technicians have learned to make records of their repair experiences so that they don't forget. Some make an annotation on the schematic diagram, or somewhere in the manual. Some slip a note into the file folder for that product. Some enter the information into a computer database.

Problems are less common

The high degree of reliability that most consumer electronics products exhibit is a boon to consumers. That same reliability can be a problem for technicians. These days, it's not unusual for a technician to encounter one problem in one particular product, then not see another similar problem for months, or perhaps not ever again.

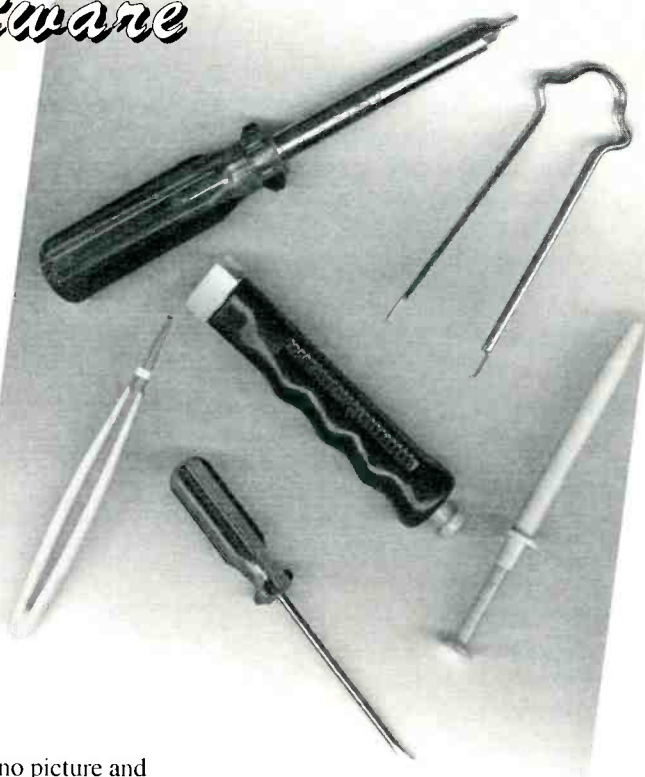

Because of this situation, it's not unusual for technicians to share tips: two or three technicians who contact each other regularly share their experiences. Or in some cases, technicians who know each other when faced with a difficult problem will call each other and ask "have you ever run into this problem?" Sometimes the technician called will have seen that problem and repaired the product, and will be able to tell the other technician exactly what to do to correct the problem in short order.

Manufacturers' tech tips

It's clear that manufacturers have long been familiar with the notion that some problems in their products occur more frequently than others, and that some of those problems may be more difficult to troubleshoot than others. Moreover, on occasion those problems have been caused by design defects, or manufacturing problems. Manufacturers have responded by publishing tech tips that alert their authorized service centers to these problems so they can cure them quickly and easily.

These manufacturers' technical servicing tips are another way in which

technicians add to their database of troubleshooting information.

Tips for sale

Information on how consumer electronics products fail, and how to correct the problem that caused the failure can save a technician a considerable amount of time. And, as we all know, time is money. It follows then, that tech tips, if they're accurate and useful, because they can save troubleshooting time, are worth money. A number of companies, generally, service centers that have a great deal of service experience, have taken advantage of this fact by compiling troubleshooting tips into books, or other form, and selling them.

Many technicians have responded to these products by buying the tips and spending less time troubleshooting and more time completing repairs.

Tips in the form of computer software

Books of tips, and tips on sheets of paper are useful. But the difficulty with tips in paper form is the accessibility of any given tech tip on any given product.

A good filing system can help, but pieces of paper can get lost, or misfiled. Books of tips make it less likely that any tips will be misplaced, but unless the books are well indexed it may still be difficult to find a given tip.

The personal computer has changed tech tips forever. Individual service centers have found ways to file their own tech tips using a computer. It may be as simple as a text file in a word processor, or as elaborate as a database file in some commercial database program. Companies that sell service tips have brought their products into the computer age, selling service tips in the form of a software program.

There are several benefits of having service tips on the computer. For one, there is no paper to get lost, misplaced, torn, or dirtied. But the most important benefit is the searchability. When the program is running, the technician simply enters the brand and model of a particular set, and the software lists that set along with all of the problem symptoms that have been reported to the company. The technician looks through the list, finds the symptom he's experiencing, if

one exists in the database, and sees what possible causes there may be.

Many of these programs, if not all of them, offer the technician the ability to add his own tips for problems that are not included in the database.

What to look for

At the end of this article is a list of companies that offer service tips software, taken from the **ES&T** Buyers' Guide database. Some of the offerings of these companies are no doubt more valuable than others. Of course, the value of a specific database would depend at least in part on how the information they contain fits in with the needs of a specific service center. For example, if you service only microwave ovens, and one of these databases has thousands of TV tips, and only a handful of microwave oven tips, it won't be very valuable to you.

Moreover, some of the databases offered by some of the vendors contain more tips than others. Some of the tips are more accurate than others. It's not within the scope of this article to rate the software offered by the vendors listed.

BOB SAVED THE WORLD TODAY...



Bob, Super-Tech extraordinaire, has a secret weapon. This amazing device allowed him to locate and replace all 34 bad electrolytic capacitors in this TV in less than 30 minutes. So instead of throwing this TV into the local landfill and adding more pollution, Bob's secret weapon enabled him to give the World a brighter future. Impressed his manager and his customer too. Bob's secret weapon? The world's best in-circuit cap checker, the **CapAnalyzer 88A** by EDS.

Smart techs know that to be productive you need to find defective components quickly and accurately.

That's why General Motors, Matsushita Industrial, Sears Service, Pioneer Electronics, Panasonic Authorized Service, NASA/Kennedy Space Center, Time/Warner Communications, NBC TV and thousands more independent service technicians have chosen the **CapAnalyzer 88A** over all of the other capacitor checkers. Check www.eds-inc.com/88users.html for actual **CapAnalyzer** users' comments as they compare their **CapAnalyzer** to the "wizards" and "z-meters" they already own. They all prefer the **CapAnalyzer** because it checks electrolytic capacitors, *in-circuit*, with 100% accuracy. No unsoldering to check out-of-circuit, no mistaking a shorted or leaky cap as good, as other "ESR" meters do, no guessing about whether a value is good or bad. With our exclusive three-color comparison chart right on the front panel, auto-discharge, multi-beep alert, and one-handed tweezer test probe, even your pet monkey could find defective caps in that problem PWM power supply, TV, monitor or VCR in a few seconds.

...NOW IT'S YOUR TURN.

So get your own **CapAnalyzer 88A**. It's only \$179. With our exclusive 60-day satisfaction-or-money-back guarantee, you risk nothing. Prepare to be amazed: your only problem will be running out of work as you take care of all of those "dogs" that you've been sitting on. We're **Electronic Design Specialists**. We make test equipment designed to make you money. Available at your distributor now, or call 561-487-6103. Check out www.eds-inc.com for all of the details.

ES&T READER SURVEY

It's a mini survey
about you.

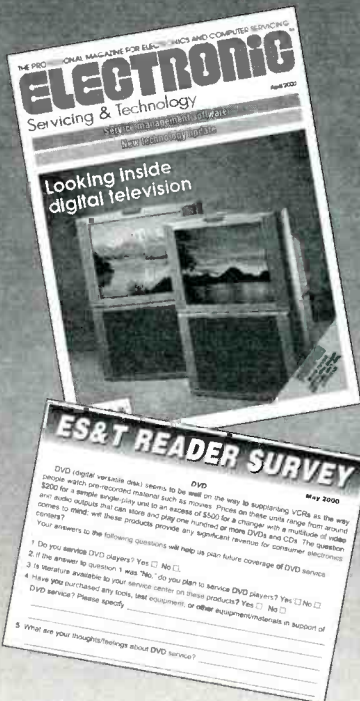

Bound into this issue is the ES&T Reader Survey card.

We would like to hear about the problems you face, the opportunities you see and the equipment you use during the course of your work day.

The postage is paid. All you have to do is fill it out and mail it.

What could be easier?

**Please fill yours out
and mail it today.**

For that, you might want to talk to a technician at another service center that has experience with a particular package. Or talk it over with fellow members of a servicer's association.

In general, though, here are a few thoughts on selecting a service tips software program.

- What is the number of tips offered?
- Are they all unique, or are some duplicates, or nearly so?
- How accurate are the tips?
- Where do the tips come from?
- Does anyone verify the tips?
- What products are covered?
- Can the center add its own tips?
- Is the software user friendly?
- Can you get a refund if the product is not suitable?

A-Tech Electronics
198 Lincoln Highway
Fairless Hills, PA 19030
215-949-0400
Fax: 215-949-8377
E-mail: sales@a-tech-inc.com
Website: <http://www.a-tech-inc.com>

Cahill Electronics
160 Main Street, P.O. Box 568
Kingston, NH 03848
603-642-4292
Fax: 603-642-7941
Website: www.cahillelectronics.com

Creative Logics Corporation
1975 E. Sunrise Blvd., Suite 722
Fort Lauderdale, FL 33304
954-713-6363
Fax: 954-713-6365
Website: www.logiserv.com

Electronic Software Developers
826 South Main Street
South Farmingdale, NY 11735-4152
516-293-0298 • 800-621-8477 (TIPS)
E-mail: Esd@bccom.com
Website: <http://www.servicetips.com>

High Tech Electronic Services
1623 Aviation Boulevard
Redondo Beach, CA 90278
310-379-2026 • 800-289-3001
Fax: 310-379-9608

Higher Intelligence Software
60 Farmington Lane
Melville, NY 11747-4019
631-643-7740 • 800-215-5081

ICM Components
1545 Sawtelle Blvd., Suite 21
Los Angeles, CA 90025
310-268-1005 • 800-748-6232
Fax: 310-445-5003
E-mail: icmsteve@worldnet.att.net
Website: <http://www.icmcomp.com>

KDTV Software
514 3rd Street
Aurora, IN 47001
812-926-4321 • 888-537-8477
Fax: 812-926-1014
E-mail: ken@servicesoftware.com
Website:
<http://www.servicesoftware.com>

M.I. Technologies
3310 E. Peterson Road
Troy, OH 45373
937-335-4560
Fax 937-339-6344
E-mail: 335@bright.net
Website:
<http://www.mitechnologies.com>

Radio World.com
1 Herald Square
Fairborn, OH 45324
937-878-9878
Fax: 937-878-1902
Website: www.radioworld.com

SyncPulse Systems
P.O. Box 4503
Sunland, CA 91041
818-353-9595
Fax: 818-353-7016
E-mail: syncpulse@compuserve.com
Website:
<http://www.syncpulse.com>

Tech. Info. Procurement Serv.
P.O. Box 1681
Forest Park, GA 30051-1681
770-968-3715
Fax: 770-968-3715
E-mail: Tipsinc@mcenter.com
Website:
<http://www.mcenter.com/tips/>

TV Man Tech Tips Inc.
8614 State Road 84
Fort Lauderdale, FL 33324
954-349-2455
800-474-3588
E-mail: Tvman@safari.net
Website:
<http://www.safari.net/tvman>

Photofacts

GE	
TX825TD	4292
13GP210BF04	4292
13GP210BF14	4292
13GP210BF24	4292
PANASONIC	
AP319	4289
AP323	4289
CT-9R11A	4293
CT-9R11CA	4293
CT-13R50DA	4291
CT-13R51DB	4291
CT-27SF36A	4289
CT-27XF36CA	4289
CT-32SF36A	4289
CT-32XF36CA	4289
D243M	4293
MAP328	4291
MHP328	4291
ND243M	4293
PHILIPS MAGNAVOX	
13PR19C121	4295
RCA	
CTC197AH3	4296
F27681GYFE1	4296
F27681GYXX1	4296
SANYO	
AVM-2558C	4298
AVM-2558G	4298
AVM-2558S	4298
AVM-2568C	4298
DS25580	4298
DS35750	4286
G5V-2558C0	4298
G5V-2558G0	4298
G5V-2558S0	4298
G5V-2568C0	4298
25580-00	4298
35750-00	4286
TOSHIBA	
CE19T11	4287
CZ19T31	4287
CZ27V51	4297
TAC9906	4287
TAC9907	4287
ZENITH	
A19A11D4	4288
B25A30ZC	4294
B25A74R	4290
B25A76R	4290
B27A74R	4290
B27A76R	4290
VR4275HF	VCR-321
VRC4265HF	VCR-321
VRC4275HF	VCR-321

Electronic Technicians Association - ETA
and
Satellite Dealers Association - SDA
present
The Ultimate Customer Service Specialist Study Guide

CSS-2

The second edition of this popular CSS Study Guide is now in print.

- Twice the number of pages**
- Twice the chapters**
- Dozens of new practice quiz questions**

Sales-marketing-service relationships; Technoliteracy; Safety; Company standards; Dependability; Teamwork; Work ethics; Problem solving; Company loyalty; Telephone techniques; Controlling your emotions; Communications; Record keeping; Safety; Decision making; Customer service techniques; Hygiene, and more

No Service Business Should be Without One of These Unique Guides to World Class Service!

to order
Call 800 288 3824
eta@indy.tdsnet
ETA-I
602 N Jackson, Greencastle, IN 46135

Circle (61) on Reply Card



If you're planning a move in the near future, don't risk missing an issue of *Electronic Servicing & Technology*. Please give us 6-8 weeks notice if you're planning on changing your address. Just write in your new address below and mail this coupon, **WITH YOUR SUBSCRIPTION, MAILING LABEL, to:**

Electronic Servicing & Technology
25 Newbridge Road
Hicksville, NY 11801

OLD ZIP CODE: _____

Name _____

Address _____

City _____

State _____ Zip _____

IEEE-1394 FireWire: The new standard for multimedia data transport

by John A. Ross

One of the more consistent complaints that I hear from my office staff concerns the amount of cabling that trails between their computers and peripheral devices: printer, scanner, zip drive, monitor, and other essential devices. Things got even worse when we added an image capture card to one of the computer systems so that we could transfer images from our video camera to our new web site.

As we completed this last task and attached the cables to our older Pentium, one of our younger employees pointed out that many Macintosh computers arrive with a serial bus called FireWire. According to our newest technology advisor, FireWire, or IEEE-1394, has become an industry-wide choice for a data transport system.

Implemented by Apple, Inc. as FireWire during 1986, the IEEE-1394 High Performance Serial Bus provides a method for interconnecting a variety of personal computer peripherals and consumer electronics devices at relatively low-cost and at high speeds. The Institute of Electrical and Electronics Engineers adopted the IEEE-1394 standard from the original Apple specifications and accepted the standard in 1995.

As consumer demand for high-resolution quality becomes greater, digital devices generate large volumes of data and require additional bandwidth to transport the data. Currently, IEEE-1394 establishes high-performance multimedia connections for business and consumer electronic devices such as digital camcorders, televisions, stereos, digital video disks, set-top boxes, mixing consoles, and music keyboards, along with hard disk drives, printers and scanners, and docking stations for portable computers.

Ross is a technical writer and microcomputer consultant for Ft. Hays State University, Hays, KS.

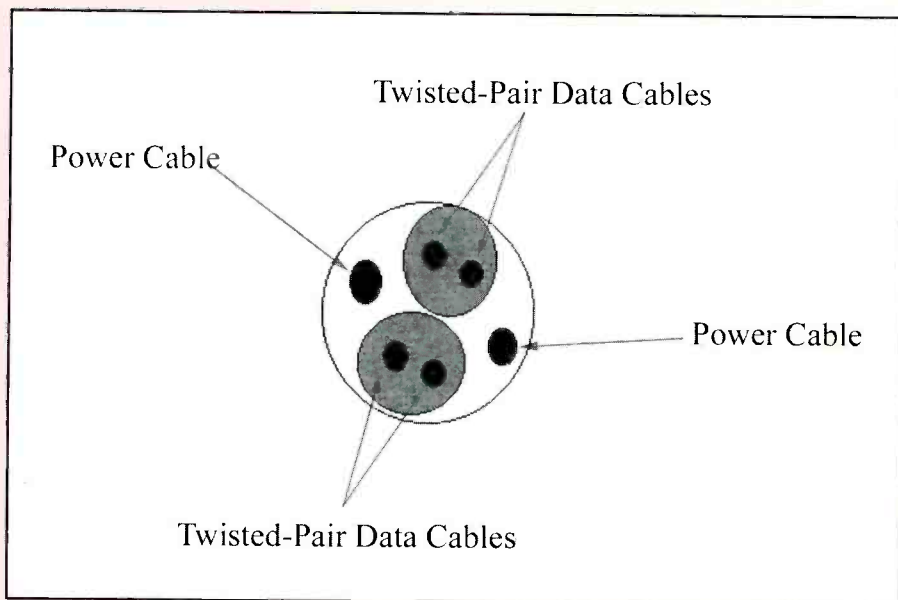

Figure 1. The use of universal Nintendo Game Boy connectors, such as shown here makes connection of a number of devices much easier using IEEE-1394.

Table 1 shows the bandwidth requirements for multimedia applications.

The importance of FireWire as a data transport medium when we compare the bandwidth carrying capabilities of standard input/output buses shown in Table 2 with the multimedia requirements listed in Table 1. With the exception of Ultra Wide SCSI (small computer system interface) and Ultra 2 SCSI, IEEE-1394 provides the largest bandwidth capability. As the remainder of the article shows, however, IEEE-1394 offers several distinct advantages.

In addition to superior bandwidth capabilities, IEEE-1394 provides a completely digital interface that allows devices to process the digital information without the expense and degradation caused by digital to analog conversion. The use of a digital interface eliminates devices such as video capture cards and provides an entirely digital data path. As a result, a monitor, computer, or digital VCR could accept the digital data and either display or store when appropriate. From a video editing

point of view, a digital video camera applying the IEEE-1394 standard does not require the use of analog video computer frame buffers for the capture of digital video.

Looking under the IEEE-1394 hood

From a technical perspective, the Serial Bus Management found with IEEE-1394 combines low-cost connectivity with:

- arbitration timing,
 - assignment of a device as the cycle master
 - assignment of a channel identification number, and
 - error checking,
- to provide configuration control of the serial bus.

Although IEEE-1394 may seem to operate as a network interface, the standard relies on the use of a serial bus to establish a simple point-to-point connection that allows scalable capability with technology improvements. The bus can connect a large number of peripherals easily and inexpensively. In addition,

Table One — Multimedia Bandwidth Requirements

<i>Image Type</i>	<i>Bandwidth Requirement (megabits per second)</i>
640 x 480 Digital Video Image (30 frames per second, 24 bit color)	221 Mbps
640 x 480 Digital Video Image (15 frames per second, 16 bit color)	74 Mbps
320 x 240 Digital Video Image (30 frames per second, 24 bit color)	55Mbps
320 x 240 Digital Video Image (15 frames per second, 16 bit color)	18Mbps
High Quality Audio	18Mbps
Digital Audio Data (44,100 audio samples/sec) (16-bit audio samples) (2 audio channels for stereo)	1.4 Mbps
Reduced Quality Audio Digital Data (11,050 audio samples / sec) (8-bit audio samples) (1 audio channel for monaural)	0.1Mbps

Serial Bus Management data transmission commands consist of simple, straightforward functions such as a write to the address of the peripheral or a read from its address.

Arbitration timing takes place through a bus configuration that sends a 125 microsecond-long start of frame timing indicator in the form of a timing gap. With the timing indicator in place, time slots for isochronous channels one and two take the next place in the frame (isochronous means equal or uniform in time, or performed in equal intervals of time). The particular applications determine the number of required isochronous channels and the required bandwidth for each channel.

Low-cost connectivity occurs through the use of isochronous, or just-in-time, delivery that allows the implementation of time-critical multimedia interfaces and Serial Bus Management. Even with the high data transport speeds seen with IEEE-1394, just-in-time delivery ensures that multimedia data receives the appropriate bandwidth when needed.

Once arbitration timing establishes the isochronous channel slots, the bus can ensure the delivery of the channels and sufficient channel bandwidth for the application requirements.

Then, the bus establishes the isochronous channel IDs that precede the sending of the packet data. During the data transport process, the receiver monitors the incoming channel ID of the data and accepts only data with the specified ID. The channel IDs contain the addressing information for both the sending and

receiving stations. Given the operating characteristics of isochronous data transmissions, even low-speed transmissions using IEEE-1394 support two simultaneous channels of broadcast-quality video and CD-grade stereo audio.

IEEE-1394 also offers asynchronous data transfer so that interoperability with existing printers and modems can exist as well as command and control for new devices. IEEE-1394 devices with that rely on different data transfer rates may interconnect. As a result, backward compatibility with devices having slower transport rates exists and current 100 Mbps devices can operate properly with bus configurations that involve 200 and 400 Mbps devices. Arbitrary timing allocates any time that remains from the isochronous data transfer for asynchronous communication purposes.

With asynchronous data transfer, equipment sends data in one direction. In turn, equipment on the receiving end responds with an acknowledgment after receiving the packet. The IEEE-1394 standard improves throughput by allowing the sender to continue transmitting data until 64 outstanding transactions exist. If the sending station receives a negative acknowledgment, IEEE-1394 error correction and recovery begins.

We can look at the IEEE-1394 interface with a digital video camera as an example of the uses of isochronous and asynchronous data transfers. The isochronous channels provide a direct path for the actual video data from the camera to other IEEE-1394-connected devices. Because of the just-in-time

qualities of isochronous data transfer, the devices do not require collision detection. Control data used for tasks such as powering on the video camera transmits in the asynchronous mode.

The OSI model of layered architecture

One of the more important issues to consider with IEEE-1394 is the purpose of the standard. As mentioned earlier, IEEE-1394 is a data transport software and hardware standard capable of carrying multimedia information at data transfer rates that range up to 600 Mbps. Given this definition, the format of the content carried over IEEE-1394 must conform to the IEEE-1394 data transport standard. All this corresponds with the OSI model of layered networking architecture. (OSI is the abbreviation for "open systems interconnection," or "open systems interconnect." The concept, developed by ISO, the International Organization for Standardization, allows computer systems from different manufacturers to communicate with each other.)

With the OSI model, three basic categories integrate with one another. The categories include:

- protocols: The rules and encoding specifications for sending data. The protocols also determine whether the network uses a peer-to-peer or client/server architecture.
- topology: The geometric arrangement of devices on the network. For example, devices can be arranged in a ring, star, or in a straight line.

**If you enjoy
Amateur Radio,
you'll enjoy**



CQ

It's a different kind of ham magazine.

Fun to read, interesting from cover to cover, written so you can understand it. That's *CQ*. Read and enjoyed by over 90,000 people each month in 116 countries around the world.

It's more than just a magazine.
It's an institution.

CQ also sponsors these fourteen world-famous award programs and contests: The *CQ* World-Wide DX Phone and CW Contests, the *CQ* WAZ Award, the *CQ* World-Wide WPX Phone and CW Contests, the *CQ* World-Wide VHF Contest, the *CQ* USA-CA Award, the *CQ* WPX Award, the *CQ* World-Wide 160 Meter Phone and CW Contests, the *CQ* World-Wide RTTY Contest, the *CQ* 5 Band WAZ Award, the *CQ* DX Award, and the highly acclaimed *CQ* DX Hall of Fame.

Accept the challenge. Join the fun.

Read **CQ**

Also available in the Spanish language edition. Write for rates and details.

SUBSCRIBE TODAY!

CQ The Radio Amateur's Journal
25 Newbridge Road
Hicksville, New York 11801

Please start my *CQ* subscription with the next available issue.
Enclose payment or charge information with order. Term and rate (check one):

	USA	VE/XE	Foreign
1 Yr	<input type="checkbox"/> 27.95	<input type="checkbox"/> 40.95	<input type="checkbox"/> 52.95
2 Yrs	<input type="checkbox"/> 49.95	<input type="checkbox"/> 75.95	<input type="checkbox"/> 99.95
3 Yrs	<input type="checkbox"/> 71.95	<input type="checkbox"/> 110.95	<input type="checkbox"/> 146.95

Name _____

Address _____

City _____

State _____ Zip _____

() Check () M/C () VISA
() AMEX () Discover

Card No. _____

Expires _____

Signature _____

(Signature Required on all charge orders)
Please allow 6-8 weeks for delivery of first issue

Ph: 516-681-2922 FAX: 516-681-2926

• media: Devices can be connected by twisted-pair wire, coaxial cables, or fiber optic cables. Some networks do without connecting media altogether, communicating instead via radio waves.

Protocols

In some ways, any type of connectivity standard faces the same problems encountered by world travelers. Along with accepting new cultural attitudes, travelers may also face language barriers. Both the cultural attitudes and the language barriers work as analogies for compatibility issues seen with networks. With networks, protocols — or a consistent set of operating standards — establish compatibility between communications systems.

Protocols describe a set of rules and methods used by devices to communicate over a network. In the most basic sense, the use of a protocol guarantees that each device connected to the network uses the same language. A very simple protocol may specify that numeric values indicating message length constitute the first three characters of each message. The remainder of the message would consist of the actual information. When the receiving program accepts the message, it recognizes that the first three characters indicate length and do not show as part of the message.

Layers of protocols

The OSI model for networking relies on different sets of protocols for different layers. Each layer consists of a program or a set of programs that provide services for the next higher layer or set of layers. The highest layer provides services to the user. Protocols also use layers as a format for communication and providing services. A protocol establishes:

- The type of error checking used for data compression;
- How a sending device will show that a message is complete; and
- How a receiving device will show that it has received the message.

Because a layer provides services only to the layer above and uses services only from the layer below it, any change to any given layer affects only the layer above. The concept of layering breaks a single large program into parts according to function. As a result, the manage-

ment and editing of the program becomes easier.

IEEE-1394 protocol layers

IEEE-1394 relies on a Physical Layer, the Link Layer, and the Transaction Layer along with the Serial Bus Management process that connects to all three layers. To transmit data, a 1394 device first requests control of the physical layer. While the Physical Layer interfaces with the 1394 cabling and connectors, the other layers establish rules for working with the application. In addition to the actual data transmission and reception tasks, the Physical Layer also ensures that all devices have access to the bus.

The Link Layer provides data packet delivery service for both the asynchronous and isochronous delivery of data packets. While those processes occur, the Transaction Layer supports the asynchronous protocol write, read, and lock commands. A write sends data from the originator to the receiver and a read returns the data to the originator. Lock combines the function of the write and read commands by producing a round trip routing of data between sender and receiver including processing of the data by the receiver.

IEEE-1394 topology

IEEE-1394 establishes data transport versatility through a non-proprietary method of interconnecting devices through an I/O port. In addition, IEEE-1394 offers a scalable architecture and a peer-to-peer topology. The use of a scalable architecture provides consumers with the option of mixing 100, 200, and 400 Mbps devices on a single bus. As a result, IEEE-1394 can handle an enormous amount of activity on the bus.

The flexible topology supports daisy chaining and branching for true peer-to-peer communication. Using a peer-to-peer interface allows the dubbing from one camcorder to another without the use of a computer.

In addition, peer-to-peer also allows multiple computers to share a given camcorder without any special support in the camcorders or computers. Each IEEE-1394 bus segment can handle up

(Continued on page 39)

Table 2 – Bus Types and Bandwidth Carrying Capabilities

<i>Bus Type</i>	<i>Bandwidth in Thousands (Kbps) and Millions (Mbps) per Second</i>
Apple Desktop Bus	10Kbps
Microcomputer Serial Port	230Kbps
GeoPort Serial	2Mbps
USB	12Mbps
SCSI-2	80Mbps
Ultra-Wide SCSI	320Mbps
IEEE-1394 or FireWire	400Mbps
Ultra 2 SCSI	640Mbps

to 63 devices on one chain. As a result, IEEE-1394 connectivity extends through disk drives, digital audio hardware, and digital video hardware.

The IEEE-1394 standard supports connectivity growth in that it allows the connection of more than 1000 bus segments by bridges. During operation, the bus bridges pass selected data from one bus segment to another. On the individual segments, devices remain separated by a maximum of 4.5 meters without the use of repeaters. Extensions to the IEEE-1394 standards have increased the distance to 25 meters.

In addition to the use of cables, repeaters and bridges, the IEEE-1394 standard also specifies the use of a backplane that extends the serial bus internally to a device. The internal 1394 bus may operate as a standalone option or integrate into another backplane. The application of the IEEE-1394 backplane could allow the direct access of an internal 1394 hard disk drive installed in one computer system by another computer connected through the backplane.

IEEE-1394 media

All this causes IEEE-1394 to appear as a complex set of devices and rules. However, the consumer has a much simpler view of the interface. The IEEE-1394 serial bus uses the thin serial cable to replace the typical large and more expensive interface cables. Going back to its Game Boy origins (it is used in Nintendo's Game Boy video game), IEEE-1394 cable connectors place the electrical contacts within the structure of the connector to minimize any shock hazard and to protect the contacts from

deterioration. The standard IEEE-1394 shielded cable contains six wires with data traveling through two shielded, twisted pair, 28AWG transmission lines. To establish a transmit/receive connection, the two twisted pairs cross in each cable assembly.

The remaining two 22AWG wires apply voltage to remote devices. With this, the IEEE-1394 standard specifies the application of 8Vdc to 40Vdc at a maximum of 1.5A when shut down to maintain physical layer continuity and provide power for any device connected to the bus. The voltages may come from the controlling device such as a computer, VCR, or audio receiver.

Unlike SCSI devices, IEEE-1394 devices do not require terminators, device IDs, or extensive configuration. The use of universal Nintendo Game Boy connectors such as those shown in Figure 1 makes IEEE-1394 much easier to connect a number of devices. Given "hot-pluggable" capabilities, IEEE-1394 allows consumers to add or remove devices with an active bus.

For the purposes of allowing daisy chaining and establishing tree topologies, IEEE-1394 devices can accommodate multiple connectors. The application of "plug and play" eliminates the need for address switches or other methods used to reconfigure the bus. Typically, the phrase, "plug and play" takes us to the world of microcomputing where the operating system recognizes the installation of a new device. With IEEE-1394, "plug and play" extends beyond the computer and to the interface cabling. IEEE-1394 automatically recognizes and configures for any new device

attached to the cable. Disconnecting the device causes the software/hardware standard to automatically reconfigure.

Sony Digital Video camcorders and Digital VCRs rely on a smaller and lighter IEEE-1394. The four-conductor cable does not contain the power wires. In addition, the Sony cables terminate with smaller, four-prong connectors that require the use of an adapter cable when used with other IEEE-1394 devices. The adapter features four prongs on one side and six on the other while connecting only the data lines.

Summary

Applications for the IEEE-1394 data transport standard continue to surface. As an example, the music industry has selected IEEE-1394 as the next generation standard interface for electronic musical instruments and high performance music editing systems. In a similar move, VCR manufacturers have focused on IEEE-1394 as the video interface for next generation VCRs. VESA, the Video Electronics Industry Standards Association, has established IEEE-1394 as the backbone for a proposed home distribution network. As a result, IEEE-1394 will gain acceptance with set-top boxes, high-definition televisions, third-generation satellite receivers, and Internet appliances.

Another avenue for IEEE-1394 usage involves internetworking. As the implementation of ATM (asynchronous transfer mode) networks increase, applications for IEEE-1394 will continue to evolve because of an ATM-similar packet structure found at the IEEE-1394 data transport level. Although ATM could become the standard method for delivering high-speed, worldwide voice/video/data over public switched networks, it remains too expensive for consideration as an interface between disk drives, cameras, and desktop computers. For example, a network server could load MPEG-2 compressed data from disk storage and then transmit the data over great distances along ATM, Ethernet, or other network technologies. IEEE-1394 could work as a complementary bridge for those high-speed networks and allow the distribution of video-on-demand applications between the home, factories, offices, and even vehicles. ■

Serviceing a Philips DVD: The power supply

by Bob Rose

I have read several articles about the development of the DVD player, or Digital Versatile Disk player. Those articles described in varying detail the process used to encode information on an audio-size CD, the composition of the CD itself, and how the DVD player retrieves the information. Building on those articles, I propose to discuss the servicing aspect of DVD players, or more specifically, a particular DVD player.

DVD players as an opportunity for service

Before I talk about servicing this new piece of technology, I want to deal with

Rose is an independent consumer electronics business owner and technician.

a comment from a manufacturer's publication, to wit, that DVD technology creates new income opportunities for the service industry. I thought as I read the comment, "Maybe, maybe not."

A new product certainly means a new service opportunity. But how much income the new product generates remains to be seen. Some companies have limited service opportunities from the start. One major manufacturer, for example, requires the owner of a defunct in-warranty DVD player to contact them and make arrangements to ship the player to one of their factory service centers, effectively eliminating the local service center from the service loop. Moreover, as of this writing, I haven't seen a single piece of literature

from that manufacturer dealing with their product. I can't service one of those DVD players in warranty, and I can't service it out of warranty if I don't have decent information. Another manufacturer has a DVD player on the market but has limited service to certain circuits only, replacing others using a "modular approach." I have seen two of their players, both of which I had to send to a factory service center for a "software update." We get paid \$15.00 for handling the unit, a fee that just barely pays the cost of shipping. Not much money there either.

In the interest of fairness, other companies have left the service door open from the start by providing manuals and other bits of service help as they shipped

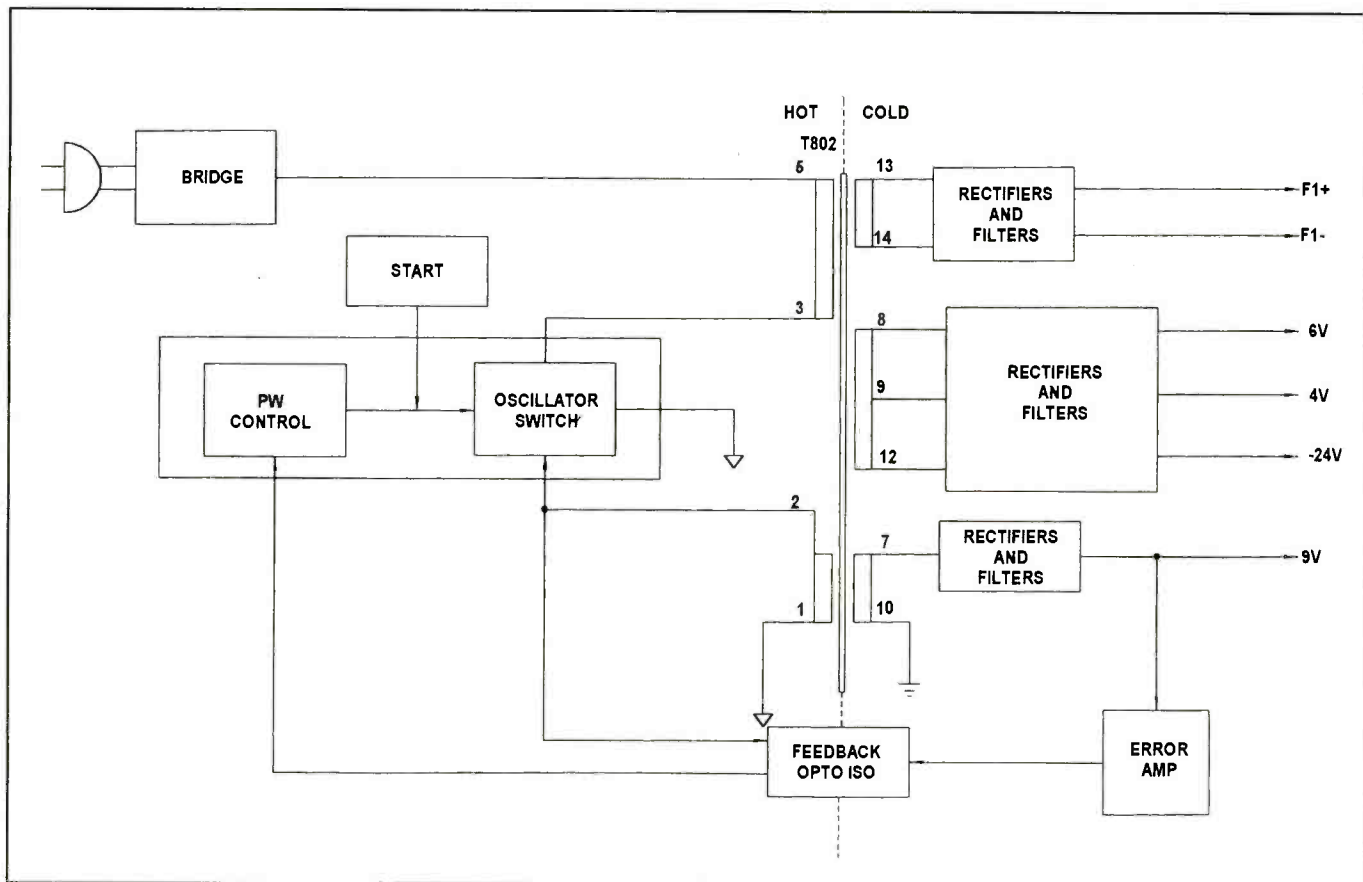

Figure 1. The DVD 400/420 uses a free running, pulse width modulated power supply mounted on a separate circuit board, shown here. Since the primary side of the power supply is reference to HOT ground, you must use an isolation transformer when troubleshooting.

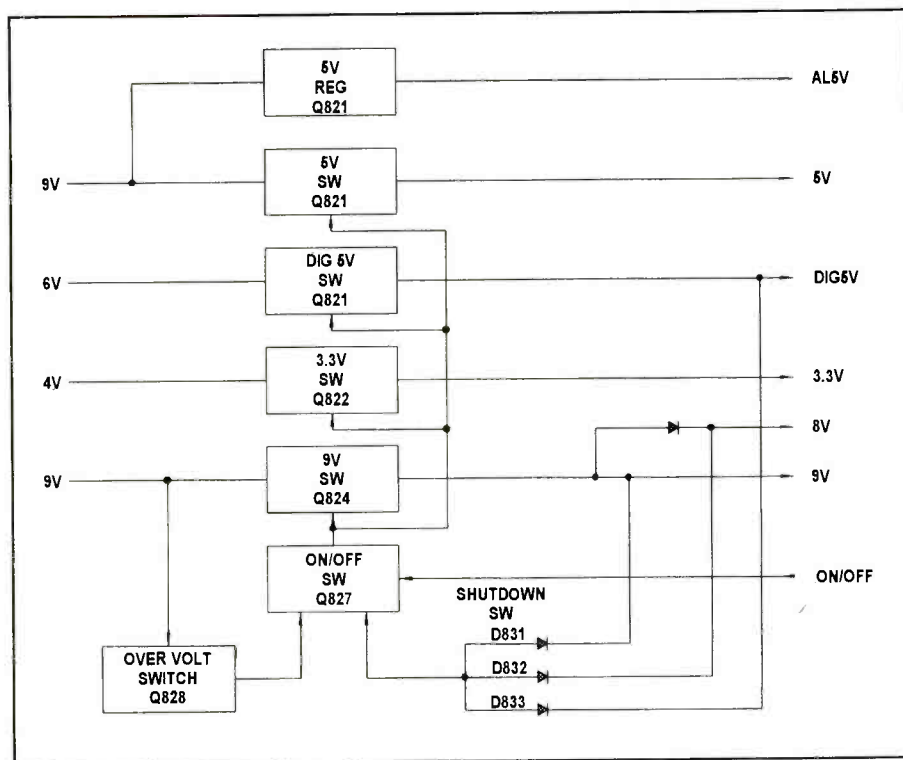

Figure 2. Block diagram of the secondary voltage outputs in the DVD 400/420.

their products to the retail stores. However as of this date, Philips is the only one that has offered any technical training, and it was fairly brief. Philips has also provided service information beyond the initial training by releasing a new DVD training tape, which I will mention again in a few sentences.

If prices keep on falling, DVD's will certainly go the way of VHS VCRs. Why pay, let us say, \$100.00 to get one serviced, and that's a reasonable figure considering the complexity of the product, when you can buy a new one for \$50.00 more? I am not saying that we can't make some money servicing these complex goodies. They have a few mechanical "weak spots" like the loading tray, that just seem cry out, "I'm going to foul up." The sled on which the optical block rides will also occasionally jam, and the lens will have to be cleaned because it seems to attract dust. Circuits like the power supply will also fail, giving us an opportunity to use our skills.

The question is, "Is the DVD technology going to be a significant source of income, or just something we use to 'fill the cracks' between major repair jobs?" I don't expect it to amount to more than something we use to supplement our

income, providing us a few jobs to do between the major ones. If our profession receives an economic boost, I believe it will come from servicing the large-screen television sets, especially the much-touted digital products.

Magnavox DVD 400/420

A generic approach to servicing DVD players has its place because it outlines a process that can be applied to almost any brand. But I find specific applications of the servicer's art a better approach because it not only teaches me how the device works, and how devices like it work, but also the "quirks" inherent in that specific device. It is true a DVD player is a DVD player, but there are differences among the brands just as a TV is a TV with the understanding that there are differences among them. Therefore, I have chosen the Magnavox DVD 400/420 as the basis for my discussion.

Service aids

Before getting to the DVD, let's talk briefly about service aids. Philips makes available several resources to help the technician service the DVD 400/420. You might want to investigate technical training manual ST4615. If the price

hasn't gone up, expect to pay \$14.95 for it. If you decide to purchase it, I believe you will get an excellent return on your investment. You may also purchase a training video tape, "What's New DVD 1999," by ordering VT182. Again, the product is well worth what you pay for it. Manual 5592 covers the DVD400 while manual 1841 covers the DVD 420. These are on paper and are available from Philips.

If you need this information, contact Philips Technical Training, 401 East Old Andrew Johnson Highway, Post Office Box 555, Jefferson City, TN 37760.

Place the order by phone if you prefer using the number 423-475-0108 or by fax using the number 423-475-0221.

The power supply

I like, as they say, "to begin at the beginning." So, let's talk first about the power supply, leaving a discussion of the other circuits for another time. The DVD 400/420 uses a free running, pulse width modulated power supply mounted on a separate circuit board. Since the primary side of the power supply is reference to HOT ground, you absolutely must use an isolation transformer when you begin to poke around inside it.

A block diagram

I believe you can get a pretty good feel for the power supply by studying its block diagram (Figure 1). While you look over Figure 1, let's take a stroll through it. As we stroll through the block diagram, I will point out what each block does without getting specific, leaving specific explanations for the full discussion of the power supply in just a few paragraphs.

Voltage from the ac line is applied to the bridge to produce about 160Vdc. The 160V leaves the bridge rectifiers and main filter capacitor and goes to two circuits. It goes first to the start up circuit to give the oscillator-switch a "let's get moving" kick. It also goes through pins 6 and 3 of transformer T802 to the collector of the switching transistor inside the oscillator-switch to provide B+ for the power supply.

Feedback from pins 1 and 2 of T802 drives the oscillator section of the oscillator-switch. This voltage also drives the pulse width control circuit through the feedback isolator (an opto-isolator) to

control the on time of the switch in order to maintain the output voltages at their correct levels.

The outputs of the secondary windings of T802 are rectified and filtered to produce these voltages: filament drive voltage for the display, +6V, +4V, +9V, and -24V. The engineers at Philips use the +9V line to drive the error amplifier that drives the opto-isolator that adjusts the drive level of the pulse width control.

Now shift your attention from Figure 1 to Figure 2, which is a block diagram of the secondary voltage outputs. The 6V supply drives a 5V regulator to produce an "ever 5V" for the main circuit board. A "high" from the main board turns on the on/off switch, making the 3.3V, 5V, the digital 5V and 9V supplies available to the rest of the DVD player. The 9V supply is also the source for an 8V supply.

A shutdown switch monitors the digital 5V, 8V, and 9V supplies for failure. If a short occurs on one of these lines, the switch activates and turns off all of the voltages except the 5V, -24V, and filament supplies. If the 9V source exceeds 11V, the overvoltage switch turns off the 3.3V, 5V, and the digital 5V and 9V supplies.

The full power supply

Having reviewed the block diagram, turn your attention to Figure 3 and prepare to take an in-depth look at the full power supply.

The ac voltage is rectified by D802 -D804 and filtered by C805 to produce about +160Vdc. The +160V is applied to pin 3 of Q803, the switching regulator, through pins 6 and 3 of T802 to supply B+ to the switch (labeled T-1) inside Q803. It is also applied to pin 2 via resistors R804 and R805 to provide a start up voltage for the IC.

When it starts up, transistor T1, inside Q803, causes current to pulse through the primary of transformer T802. Once the transformer saturates, the magnetic field induced in its primary collapses and reverses polarity. The reverse polarity causes the voltage at pin 2 of T802 to become negative and apply the negative voltage to the right side (the side nearest T802) of C809, turning transistor T1 off. After the field has completely collapsed, pin 2 of T802 goes positive which for-

ward biases D807 and turns T1 on, repeating the cycle.

Capacitor C809 is crucial to the operation of the power supply because it controls the operating frequency, which of course varies as the load changes. The circuit is designed to oscillate at approximately 125kHz when the unit is in standby and at approximately 55kHz when the DVD unit is playing.

When it turns on, T1 (the switch inside Q803) causes current to flow in the primary of T802. The current flow creates a magnetic field that is coupled to the secondary windings, thus magnetically coupling the energy from the primary to the secondary when T1 turns off. The secondaries produce the following voltages from which other voltages may be derived:

- (1) a +9V supply that is the source for the AL 5V and two switched voltages and is the voltage source monitored by the error amplifier;
- (2) a +6V source;
- (3) a +4V source;
- (4) a -24V supply; and
- (5) a +5V supply for filament drive.

IC821, the "control IC," is crucial to the operation of the DVD. As you see, the +9V supply is routed to it at pin 9. The IC uses the 9V to generate the AL 5V for use by the main circuit board and to generate a switched +5V and a switched 3.3V.

The job of regulation

IC821 also contains the all-important error amplifier whose job is constantly to sample the output of the +9V line and feed the results to the LED inside Q802 (the opto-coupler). If the 9V supply goes high, the error amplifier conducts harder, causing the LED to glow brighter. Notice that feedback voltage from pin 2 of T802 is connected to pin 3 of Q802. When the feedback circuit turns on the transistor portion of Q802, T3 inside Q803 turns on and turns T1 off. If the LED inside Q802 becomes brighter, the transistor portion turns on harder and also causes T3 to turn off. The power supply achieves regulation by controlling the on-time/off-time of T3. If the output voltages rise, T3 turns on and turns T1 off, causing the output voltages to lower. If the output voltage drops, T3 stays off longer, which has the effect of

keeping T1 on a bit longer, raising the output voltages.

To put it differently, the error amplifier, the opto-coupler, and T3 control the on time of T1 to maintain the +9V supply at its correct level. Since they track the +9V source, the remaining secondary voltages are also held at their stated levels.

According to the literature, the 9V line must be loaded at all times to maintain proper regulation. The circuit designers came up with an interesting circuit designed around Q821 to provide proper loading when the DVD player is in standby mode. Let's see how the circuit works by assuming that the power supply is in standby mode. Q827 will be off, holding all switched voltages in their off positions. Q826 will be on because R830, D826, and R832 will have developed sufficient bias voltage from the 9V line to turn it on. When it is on, Q826 provides a ground path through R830 for the 9V line, thus providing the loading necessary to keep the power supply in regulation until the unit turns on.

By the way, all of the power supply voltages are routed via a cable to the main circuit board. The cable terminates at a connector designated "CN801" which provides the servicer with a convenient place to check all of the power supply voltages. If you look at the extreme right hand side of Figure 3, you will see the notation "CN801" just above the 8V line indicating that each line from the power supply terminates at that plug.

The protection circuits

You may be asking, "What about excessive-current protection?" In other words, "How does the power supply keep from self-destructing when something shorts and causes it to draw excessive current?" That's a very good question. Do you see resistor R808 connected between pin 4 of Q803 and ground? It is the emitter resistor for the switch (T1). If sufficient current flows through it to develop 0.6V across it, T2 inside Q803 turns on and shunts the base drive for T1 to ground, shutting the power supply down. A neat circuit, isn't it?

I suspect you are toying with a second question, "What happens when the 9V supply goes high?" To put the question differently, "What about overvoltage

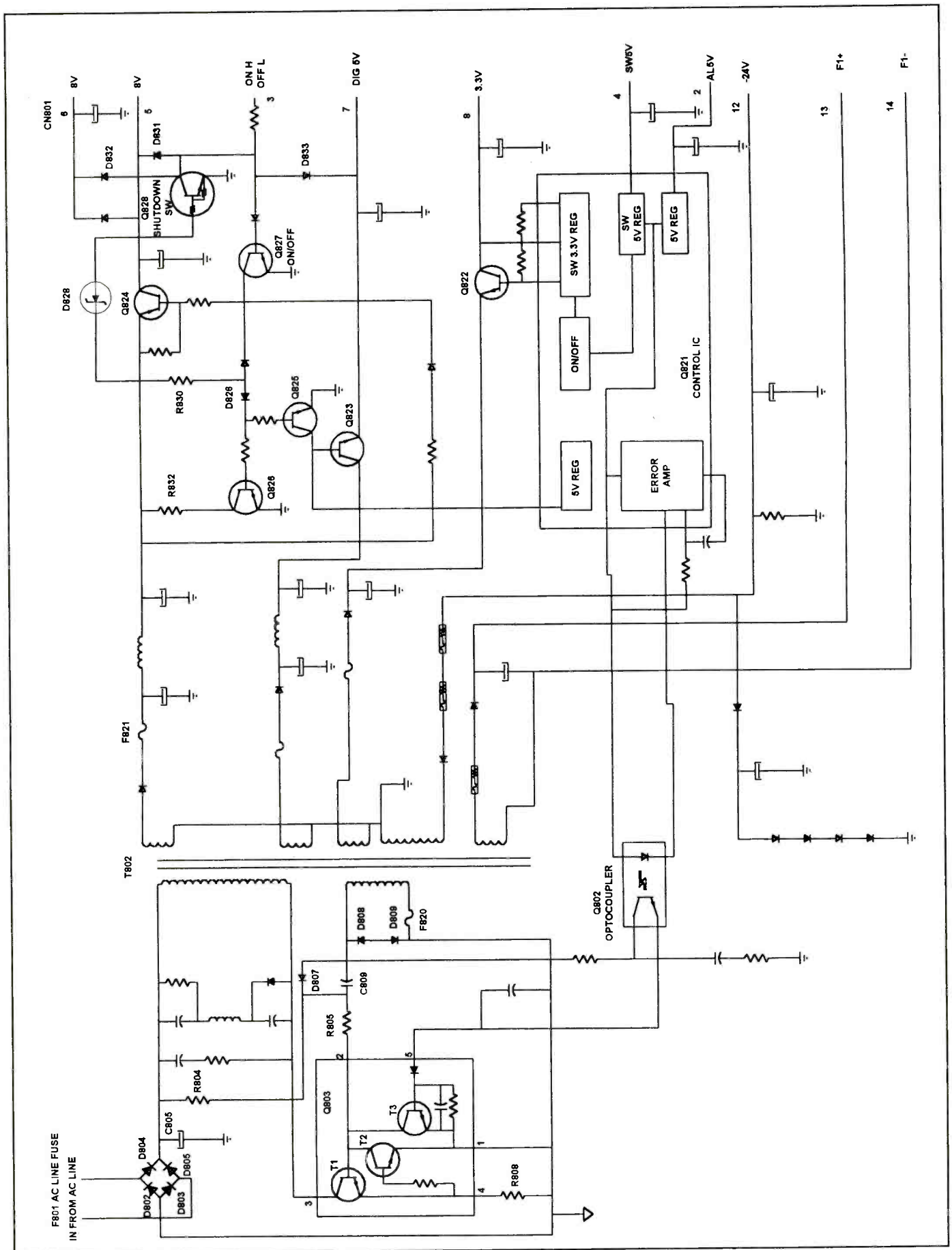

Figure 3. This schematic diagram provides an in-depth look at the full power supply in the DVD 400/420.

protection?" Follow the signal flow from pin 7 of T802 to your right until you locate D828, which in the schematic is located just above Q824, and note that its anode is directly connected to the base of Q828, the "shutdown switch." If the 9V supply exceeds 11Vdc, D828 conducts and pulls the base of Q827 low. Since Q827 is responsible for turning the power supply on and off, the power supply turns off, and the DVD shuts down.

That takes care of overcurrent and overvoltage protection. Now what about some kind of overload protection? If an overload appears on the 8V, the 9V, or the digital 5V lines, the overload permits one or more of diodes D832, D831, or D833 to become forward biased, a condition that also causes Q827 to turn the DVD player off.

By the addition of just a handful of parts, the engineers at Philips have come up with a neat way to protect the power

supply as well as the unit it supports from damage due to overcurrent, over-voltage, or overload.

From standby to full power

The power supply makes the transition from standby to full power when the main printed circuit board applies 5V to pin 3 of CN801 after the player receives a power on command. The 5V is routed by pin 3 of CN801 to the on/off control component (Q827) causing it to initiate the power on sequence.

Since it is an NPN transistor, Q827 responds to the voltage at its base by turning on, an action that produces a low at its collector. The low is routed to four other components.

1. First, it is applied to the base of Q824, a PNP transistor that quickly saturates and makes the 9V and 8V supplies available to the main circuit board via pins 6 and 5 of CN801.

2. Second, the low goes to the base of Q825. Since it is a NPN transistor, Q825 turns off, an action that permits the 5V regulator at pin 6 of Q821 to turn Q823 on making the digital 5V supply available at pin 7 of CN801.

3. Third, the low at the collector of Q827 is routed to pin 2 of Q821 to enable the 3.3V switch inside Q821 to turn Q822 on, making 3.3V available at pin 8 of CN801.

4. Fourth, the low is coupled to the base of transistor Q826 to turn it off, since the load this component provides for the 9V line when the unit is in standby mode is no longer necessary.

A few troubleshooting hints

Begin by plugging the unit into an isolation transformer set to output 115Vac. Remember, the primary of the power supply is referenced to hot ground. If you don't use an isolation transformer, you risk doing damage to the power supply and seriously damaging your test equipment, not to speak of creating a safety hazard for yourself.

The first voltage to check when you suspect a power supply problem is the AL5V that you may monitor at pin 2 of connector CN801. If it is missing, check the 9V supply on each side of fuse F821. If both voltages are missing, you may be

reasonably sure that the power supply isn't working. Remember always to check at least two secondary voltages when you troubleshoot a switching power supply. Checking just one voltage and finding it missing may mean that you have just one missing voltage.

If both voltages are missing, check the output of the bridge rectifiers at D804 for about +160Vdc. I suggest using D804 as a test point because it is convenient, but you may check for the +160V wherever it is convenient. If it is missing, check F801 and the bridge diodes. If F801 is open, check the bridge diodes, C805, and do a resistance between pins 3 and 4 to determine if Q801 has developed a short circuit.

If the +160V is present at pin 3 of Q803, check for a startup voltage of about 0.7V at pin 2 of Q801. If it is absent, check resistors R804 and R805 for an open condition. If the +160V and startup voltage are present, remember that the power supply must have feedback from pins 1 and 2 of T802 to oscillate. Therefore, check diodes D808 and D809, and fuse F820.

If the unit won't turn on and the 5V supply is present on pin 2 of CN801, unplug the connector from the main circuit board and place a jumper between pins 2 and 3 to turn the power supply on. By jumpering pins 2 and 3, you are connecting the on/off line to the AL 5V line and more or less "forcing" the power supply on. (You are also setting up a situation in which you can troubleshoot the power supply if it won't stay on.) If the switched voltages come on line, you have confirmed the correct operation of the power supply and isolated the problem to the main circuit board.

If you have to change Q803 because T1 has shorted, be sure to change R808 even if you think it hasn't been damaged. It is a low ohm resistor that is difficult to check unless you have a highly accurate ohmmeter. Because it is used to monitor the current that flows through T1, R808 is critical to the operation of the power supply. A slight increase or decrease in its value seriously impairs the correct operation of the unit. Therefore, change this resistor when you replace a shorted Q803.



**Your Ticket to
SUCCESS**

More than 40,000 technicians worldwide are Certified Electronics Technicians. ISCET offers Journeyman certification in Consumer Electronics, Industrial, Medical, Communications, Radar, Computer and Video. For more information, contact the International Society of Certified Electronics Technicians, 2708 West Berry Street, Fort Worth TX 76109; (817) 921-9101.

Name _____

Address _____

City _____

State _____ ZIP _____

___ Send material about ISCET and becoming certified

___ Send one "Study Guide for the Associate Level CET Test." Enclosed is \$14.95 (includes postage/handling). *TX residents — include 8.25% sales tax.*

ES&T

Circle (64) on Reply Card

While you have a shorted Q803 out of circuit, take a few moments, and it doesn't take long, to check every component in the primary circuit. Check each resistor against its stated value and each diode for an open or shorted condition. I assume that while you are checking these components you are examining the power supply for signs of obvious damage like burned or bulging components.

After you are satisfied that the primary-side components pass muster, shift your attention to the secondary and at least check the diodes for opens or shorts. Then install Q803 and R808 and get ready to check your work. I am tempted to instruct you to replace the opto-coupler when you replace Q803 and R808, but I leave that decision up to you. If the power supply won't regulate after you complete the repair, you certainly should replace Q802 as the next step.

Oh yes! After you have installed the new components, set the variac to 0Vac. Bring up the ac voltage slowly while you

monitor the waveform at pin 3 of Q803 and the +9V line. If things go smoothly, increase the ac voltage slowly until you have reached 115Vac. But turn the variac off immediately at any sign of trouble, like strange noises from the power supply or a waveform at pin 3 of Q803 that shows signs of severe ringing or the +9V line not tracking the increased ac voltage as it should.

Power supply checks

Here's a summary of the troubleshooting steps for a DVD player:

1. Begin by pushing the power button to see if the red power LED comes on.
2. Check the dc voltages on pins 2 through 8, 12 and 13, and 14 of CN801. If any of the voltages are missing or improper or if the power LED doesn't come on, unplug the power supply from the main board and jumper pins 2 and 3 of CN801. Then recheck the voltages on pins 2 through 8 and 12 through 14. If the voltages are still improper or missing,

you have a problem with the power supply. If the voltages are normal, you more than likely have a problem either on the main board or one of the other boards to which the power supply is connected.

3. Assume the voltages come up when you unplug CN801. Remove ac power and reconnect the power supply to the main board, leaving the jumper in place. If the voltages still don't come up, remove the connector to the front panel, reapply ac, and recheck the voltages. Repeat the process for each board until you find the one responsible for loading down the power supply. Don't forget to remove ac every time you disconnect and reconnect connectors. If you don't, you will most likely add to the damage the unit has already sustained.

That about does it for now. The power supply may look a bit complicated when you first examine it, but I believe you will find it relatively easy to troubleshoot and repair, especially after you have worked on one or two. ■

Only Our Name Has Changed

The Technical Products Division of Howard W. Sams is now Sams Technical Publishing. Same great people. Same great products. We will continue to produce PHOTOFACT® with the same detail that Mr. Howard W. Sams demanded when he created PHOTOFACT® in 1946 and will continue to publish well-written technical books under the PROMPT® Publications brand.

Check out our new and expanded website at www.samswebsite.com, and as always you can call us at 800.428.SAMS!

The logo for SAMS Technical Publishing, featuring the word "SAMS" in a large, bold, stylized font with a white outline, set against a dark rectangular background.

Technical Publishing
(formerly a division of Howard W. Sams)

5436 West 78th Street
Indianapolis, IN 46268

800.428.SAMS
www.samswebsite.com

Remote profit

by John S. Hanson

With the proliferation of affordable universal remote controls available to the consumer, it appears that defective remotes are destined to be carted to the landfill along with the computers, TVs needing a CRT, and VCRs that can't be fixed with a cleaning.

Not so! How about 90% profit on a repair that requires no parts, and only 15 minutes of your time. Now that I have your attention, read on. Why repair a

Hanson is an independent servicing technician and a retired service engineer from a major consumer electronics manufacturer.

remote? For one thing, many of the TV function modes are not available on the universal; such as Menu and Source. Without those functions, the customer has no way to change from antenna mode to cable using the remote. Another function not available on universal remote controls is time set, and source switching. Buying an original OEM replacement is out of the question. Have you checked the prices?

Repairing a remote control unit

Let's say that a customer brings in a universal remote saying, he or she can't

program all the functions. You ask, "Do you have your original remote, or did the dog eat it?" If the answer is that they still have the remote, ask to have it brought in, and call them when they can pick it up. Do not attempt a repair in their presence. Proceed to follow the repair process. In this case, I'm using a Zenith Remote manufactured sometime between 1985 and 1995 as an example. The information may apply to other brand remotes. Keep in mind, I said you can do this in 15 minutes, so pay heed to the time.

1. Remove the batteries and clean the contacts. Replace the batteries with

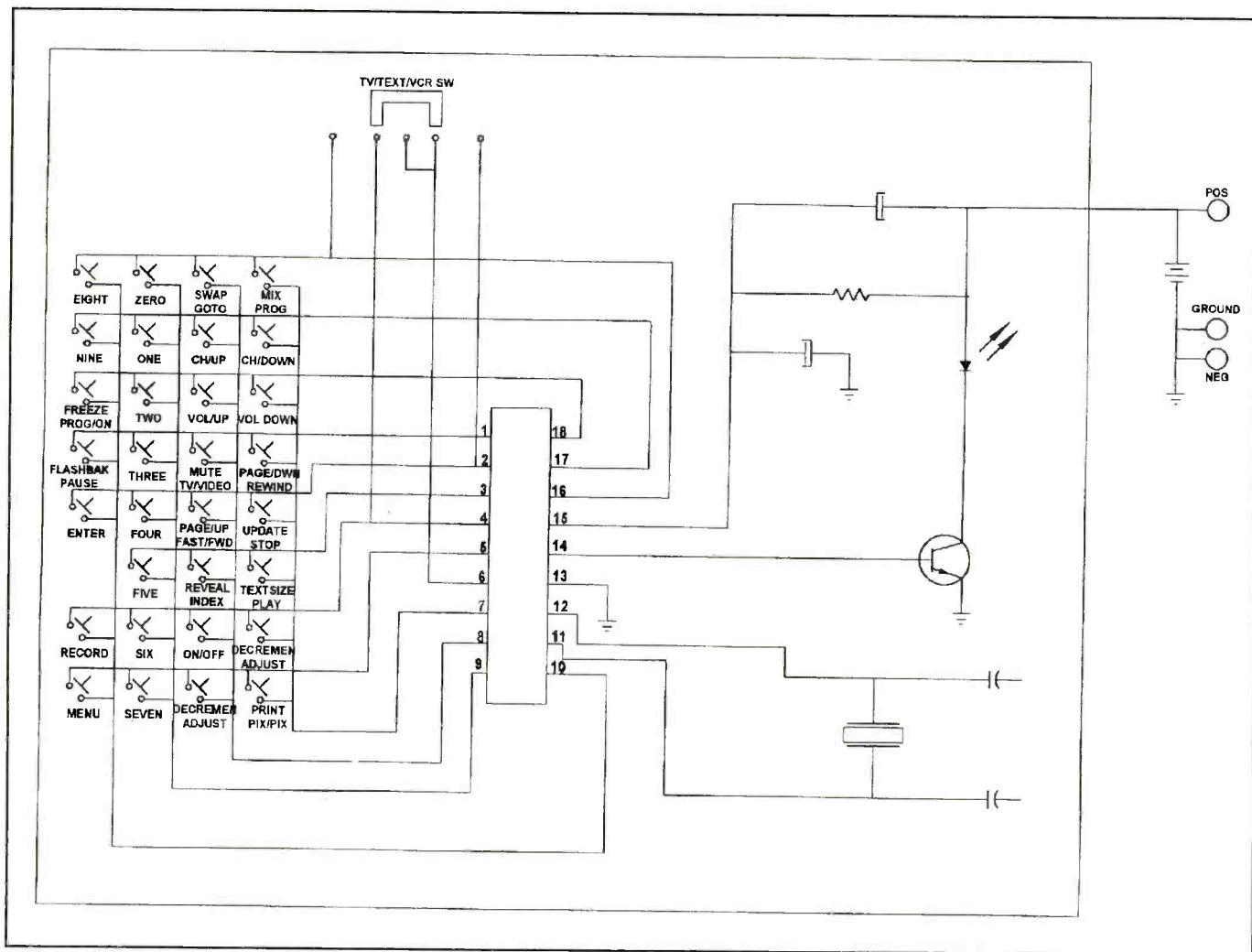

Figure 1. This drawing of a Zenith remote control manufactured sometime between 1985 and 1995 shows the functioning of a typical hand-held unit. If any of the push-button switches are dirty, the unit won't send the correct signal to the receiving unit in the TV set or VCR.

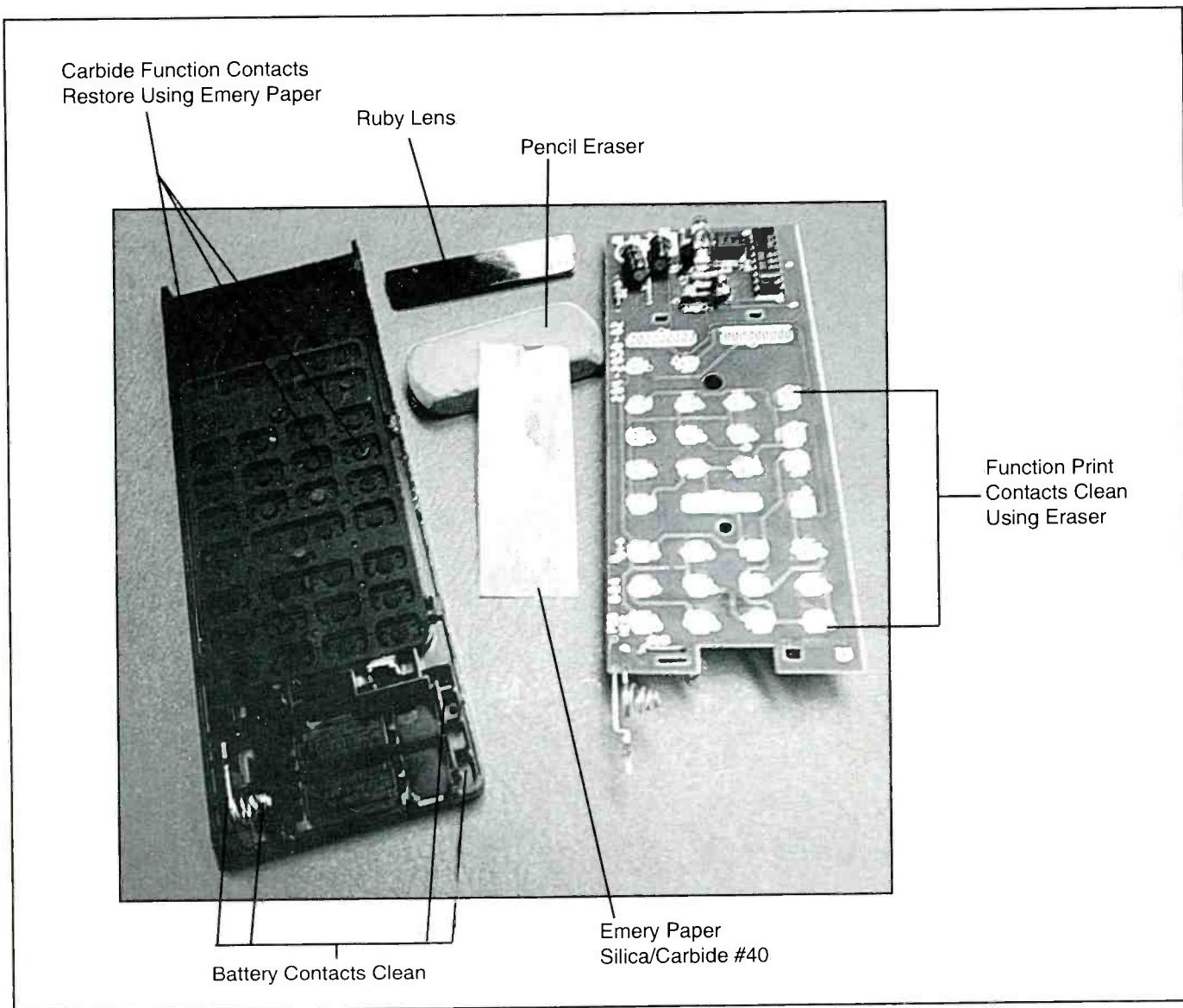

Figure 2. A new pair of batteries, and a little cleaning of contacts with an eraser and some fine emery paper may be all it takes to restore a remote control unit to operation.

known good batteries. Heed battery polarity. Clean the IR ruby lens at the front of the remote. If a TV set that the remote control will work with is not available, use an infrared indicator test card or other indicator to test keys for IR output. If any key indicates an IR output, proceed with the repair. If not, stop. Do not continue with the repair process.

2. Remove batteries, and the Cable Channel listing label on the back, and the single screw in the center. With the remote in hand, emitter lens forward, slide the back cover towards you about 1/2 inch. It may take some force. You can now lift off the back cover.

3. Next step is to remove the circuit board. Begin by unwrapping the wire on the metal tab at the lower right end of the

PC board. Press the four plastic tabs forward, and lift out the PC board. Turn the board over, and proceed to clean each of the printed circuit contacts representing each of the remote functions. Use a clean, lead pencil eraser. Do not use chemical cleaners.

4. Use a fine grade emery paper to wipe the carbon contacts on the rubber membrane. Just a wipe with the paper is necessary to expose a fresh carbon surface for each key function.

5. That's it. Now for the re-assembly. Do everything mentioned in reverse. Place the back cover about one inch back from the ruby lens, and push forward. You need to engage the six plastic tabs that act as a track to hold the back in place. With the back of the remote firm-

ly in place, replace the center screw and install the batteries.

6. Check each key for output using the television or the IR test card. Call the customer and apologize for destroying her Cable Channel label.

7. You expected 10 steps? Sorry, it really is this easy.

Summary

Remote controls have been around a long time. They are perfected and rarely fail electronically. It's the human environment that does them in. They do not like drinks, particularly soft drinks. Most can be repaired using simple steps, the rest do not make business sense to repair. Try my 6 steps to profit, and remember, to set your bench timer for 15 minutes ■

A video problem in a Zenith SR2739RX

by Bob Rose

The Zenith TV which is the subject of this article belongs to a group of chassis known in Zenith parlance as "the C-11 chassis." It is constructed on a single printed circuit board, the video output module being a break-away portion of the main board, and comes equipped with MTS stereo, SAP (Second Audio Program), surround

Rose is an independent consumer electronics business owner and technician.

sound, and may have a picture-in-picture (PIP) capability.

A quick preview of the chassis

Ten integrated circuits handle the tuner, audio-video, sync, and sweep functions in this TV chassis.

An additional one in the power supply brings the total number of ICs to 11. IC6000 is the system microprocessor. IC6001 interfaces the tuner bus with IC6000. IC6003, system reset, completes the ICs in system control. IC1200,

IC2201, and IC2202 process the video, audio, sync, and vertical and horizontal sweep. IC2100 develops vertical drive for the yoke. IC1400 and IC801 receive, decode, and amplify the audio signal while IC2200 serves as the audio-video interface. ICX3431 is the switch mode regulator, and IC4121 develops +9V from the +12V line.

I suspect you keep up with Zenith TVs, not by chassis type, but by module. If such is the case, then make a note that the module which I am about to discuss is a

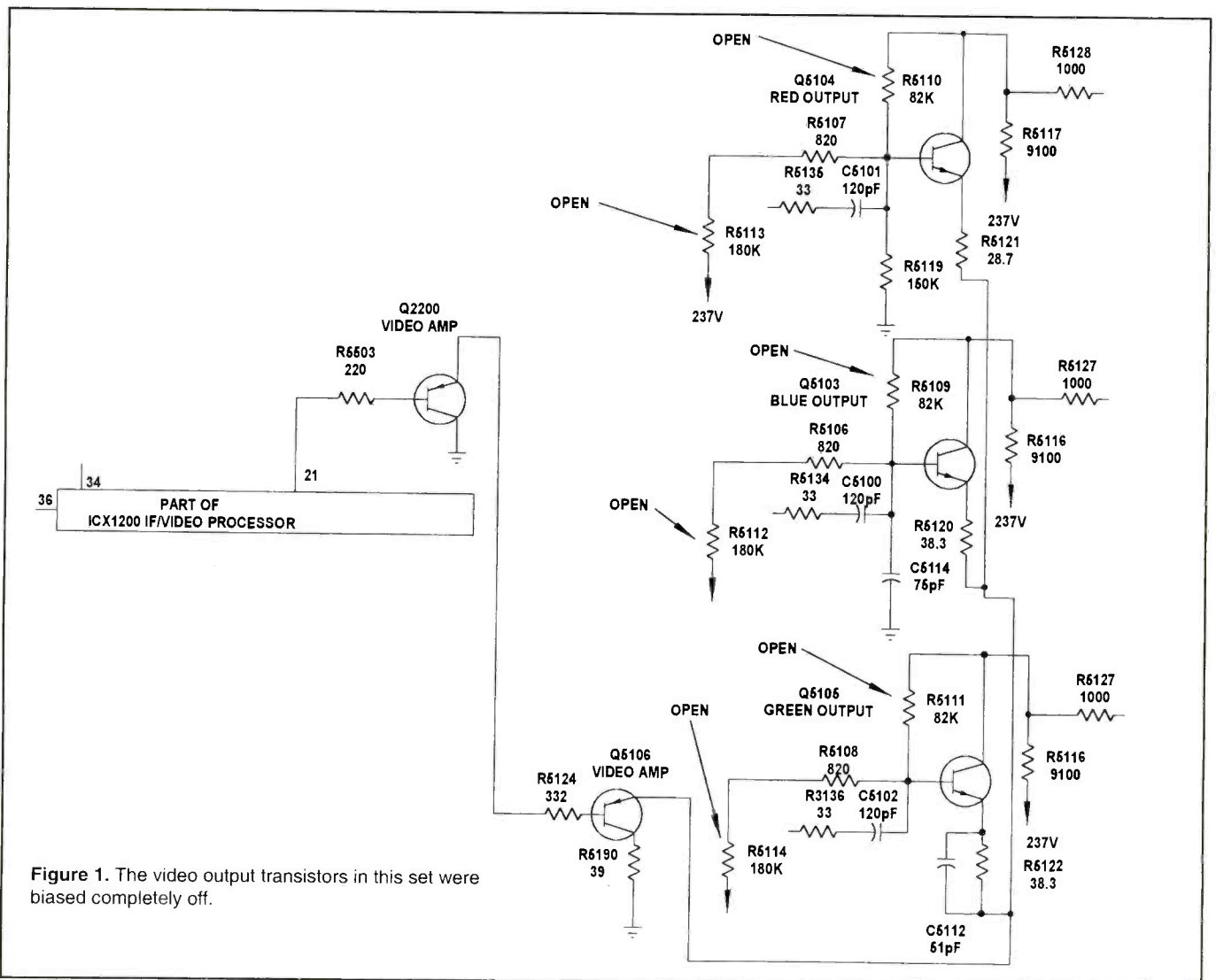

Figure 1. The video output transistors in this set were biased completely off.

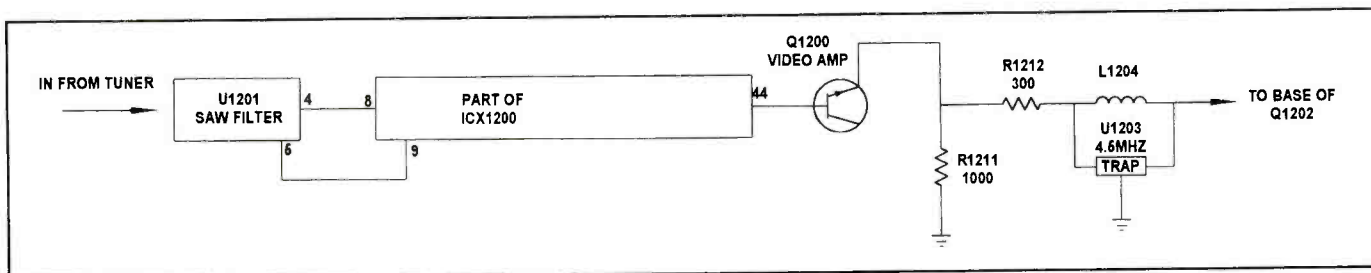

Figure 2. Video is processed in IC1200 and exits at pin 44 for further processing.

9-1553 found in a 27-inch TV. Other modules in the family include 9-1551, 9-1552, and 9-1559. If my information is correct, they are found in 25-inch and 27-inch sets in: the "System Three" line. Naturally, a problem found in one could just as easily be found in the others.

Good audio but no video

The TV in question came into the shop with the note, "Doesn't Work," tacked onto it. I put it on my bench and fired it up, noting that it came on with excellent audio but had an absolutely black screen. It wouldn't even display the customer menu. I turned the G2 voltage up to see what might be happening and noted full vertical deflection but no video and no on-screen information. I guess I ought to say I could see the on-screen menu, but the characters were so dim that I couldn't determine which menu was on the screen. If I left the G2 setting high for any period of time, I could just make out video in the deep background.

It's always best to make a few checks before you "get elbow deep" into a repair. So, I scoped the collectors of each video output transistor and found about +245Vdc on each one without even the hint of a waveform (Figure 1). The transistors were, to make a long story short, biased completely off. Yep. Obviously a problem in the video path.

I knew I needed literature to service this one. I checked Zenith's factory service literature and decided it really wasn't what I needed. Sams, according to my index, didn't publish a Photofact for the set on which I was working. So I checked a database I maintain and found a reference to Photofact 3709 which proved to be adequate to the task. It also serves as a source for the following schematic diagrams.

A preview of the video path

Video processing (luminance) in the C-11 chassis doesn't markedly differ

from other Zenith designs. IC1200, a LA7672, is the heart of the circuit. Video from the tuner enters pins 8 and 9 of IC1200 (Figure 2), is processed, and exits at pin 44. It passes through a video amp configured as an emitter follower (Q1200) and is conducted to transistor Q1202, which routes it to IC2200 (Figure 3), the audio-video switch.

The signal exits pin 14 of IC2200 and goes through another emitter follower (Q2212) before it is processed by the comb filter. The "combed" (or separated) Y and chroma enter the PIP at pins 1 and 3 of connector 4D9/9D4 and exit at pins 3 and 5 of connector 9C4/4C9 on their way back to IC1200. We are currently interested just in the Y signal that passes through the delay line and into pin 34 of IC1200. It exits again at pin 21, is processed by a video amplifier (Q2200), and is applied to Q5106 on the video output module. This transistor amplifies the signal and applies it to the emitters of each video amplifier (Q5103-5105).

Even though I have just barely mentioned the PIP, I want to emphasize the "what goes into" and "what comes out" sequence, because the PIP has the ability to cause problems in the video path. As I have said, the video signals (luma and chroma) enter pins 1 and 3 of connector 4D9/9D4. The main and PIP luma exit at pin 3 of 4C9/9C4 while the main and PIP chroma exit at pins 3 and 5. Since it is a solder-in-place module, you can't troubleshoot it by bypassing it. However, you may confirm its operations by scoping the signal as it enters and leaves the module.

The last PIP-caused problem I serviced developed like this. I turned the TV on and was greeted by a slightly blue screen that lacked full vertical deflection without a hint of video. The "what goes into" signal looked good, but the "what comes out" signal was one of the most distorted signals I had ever seen. The

best check is obviously to replace the suspected PIP. I had one in stock that I quickly soldered in place. The new PIP fixed the TV.

Back to the video problem

Now that you have an understanding of the video path, let's see if we can find out what caused this particular problem. Your reaction to a video problem in such a complicated and convoluted circuit might be like mine: you wipe the perspiration off your brow and wonder where you ought to begin because the task seems at first to be daunting. But let's begin, as they say, "at the beginning."

First, I needed a signal that isn't always changing the way an off-the-air signal is and one that I could easily recognize. So, I fired up my TV signal generator, selected the "Ten Bar Stair Case" pattern and injected it into the RF port of the tuner. Then I used my scope to see what was happening at pin 21 of IC1200 and found the video pattern undistorted and at about a 6.5V_{pp} level.

You may be wondering why I selected pin 21 as the starting point. There are a number of reasons, the most important one being that it was a good place to make a division between the beginning and the end of the video path, and it was handy. In other words, it was a convenient way of dividing the circuit into two parts. If I found the correct signal there, I knew the first half of the circuit was working and needed to focus on "what lay down stream." If I didn't find a good signal, I would have to pay attention to the circuit that lay between the tuner and the output of the video-processing chip.

You see, checking the signal at pin 21 let me know that the tuner, IC1200, the PIP module, the comb filter, the delay line, and all associated components and circuits were working properly. I had made one check and eliminated lots and lots of circuits, saving a considerable amount of time in the process.

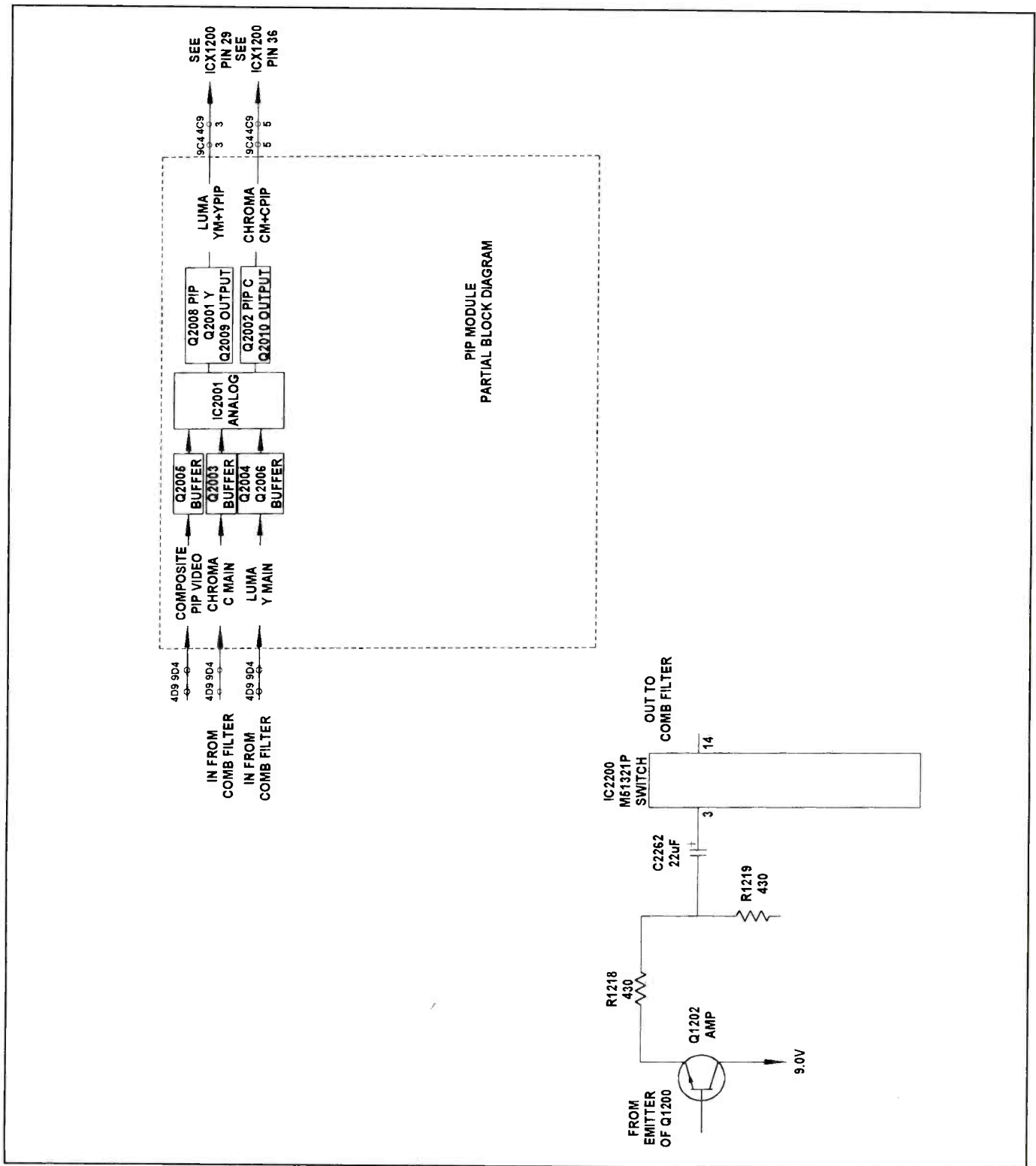

Figure 3. The PIP has the ability to cause problems in the video path.

You may be wondering, "What if the signal at pin 21 hadn't been good?" Good question. I would have selected another test point about half-way between the tuner and pin 21 and performed a second check. You save time when you are able to divide a troublesome circuit into halves with each check you make. Before

you know it, you have arrived at the problem stage and put your test probe on the problem component(s).

The second step in the elimination process

Second, I moved the probe to the base of Q5106, the video amplifier located on

the video output circuit board (Figure 1). If you work on many Zenith televisions, you know that Q5106 often causes video problems. It usually fails by developing a collector to emitter leakage that permits the video output transistors to turn fully on. When they turn on (saturate), the transistors permit excessive beam

current to flow, creating an extremely bright screen with heavy retrace lines.

Given the history of picture tube failures in Zenith television, the first thing that comes to mind when I see such a sight is, "Well, another bad picture tube." Fortunately, there is a quick test that can tell you if the tube is defective. With the CRT board on the picture tube, the voltage on the collector of each output transistor will be drastically lower than it ought to be, let's say about 100Vdc lower than the stated value. If you remove the CRT board, the voltages will still be low, indicating that the electron gun inside the picture tube hasn't caused the problem. Look, then, to the video driver transistor as the possible culprit.

However, Q5106 could open, removing video drive from the output transistors. A possible scenario, to be sure, but not likely. I found a good signal at its base and no signal on its emitter. The dc voltages were also off, but not by much. The transistor, as I suspected, checked good both in and out of circuit. This problem wasn't going to be quickly and easily solved.

Checking the video output transistors

Third, I carefully rechecked the dc voltages on the video output transistors (Figure 1) and found the voltages on their bases and emitters to be considerably off. We are dealing with direct-coupled circuits, meaning the problem could be caused by their predrivers, Q5100, Q5101, and Q5102. Was it possible that all three predrivers had failed? No, those transistors were okay, even though their bias voltages were off. Since it was possible that Q5500, the transistor that provides bias for the predrivers, had developed a problem, I checked it. It too was operating as it should be.

Now what?

Let's focus on the video output transistors for a moment. I noted that adjusting the drive controls had no effect whatsoever on their bias voltages or the quality of the dim raster. I expected at the very least that the color of the raster would change slightly as I moved each pot through its range. However, nothing happened. I have been working on Zenith products for a long time and remembered a service bulletin about a certain resistor on the video output mod-

ules of projection TVs that often opened leading you to believe that a picture tube had failed. The symptoms certainly pointed to an open bias resistor. I began my resistance checks with the resistor that logically could be causing the problem. For the sake of illustration, let's choose the green signal path. The resistor in question is R5114. It was open. That would explain the absence of green, but what about the other colors? Would you believe that R5112 and R5113 had also opened?

I replaced these three resistors and had video when I turned the set back on, but the picture still left a lot to be desired. I unplugged the set and checked another set of resistors, which, if they had opened, would have a drastic effect on the quality of the picture. I found that R5109, R5110, and R5111 had also failed. I replaced them, and I had a gor-

geous picture after I adjusted the G2 and set the gray scale.

Conclusion

I don't recall ever having to replace six resistors on a video output module, but I had to this time. Like you, I wondered why all six had failed. I thought that perhaps the picture tube had arced and taken them out. But I played the TV for several hours and even banged on the neck of the picture tube with the handle of a nut driver, and the picture never once flickered. When I concluded the job, I said to myself, "Son, I shall not soon forget you." It was one for my database and one about which I thought you might like to know.

Remember the symptom written on the repair tag: "Doesn't Work?" I filled out the invoice listing the parts I had used, and under "Service Performed," I simply wrote, "Got it to work." ■

Do You Repair Electronics?

Repair Databases for TV, VCR, Monitor, UL Audio, FCC, and more.	- Over 76,000 records - Private user forums - Live on-line chat rooms
---	---

RepairWorld.com
Electronics Corp | Herald Sq. Fairborn, OH 45324 (937) 878-9878

Circle (63) on Reply Card

Visit the **NEW**
Herman Cyberwarehouse
to order online now!



www.hermanelectronics.com



To Order Back Issues
Only \$4.00 Per Issue
Complete your collection today.

Check, Money Order, Mastercard, VISA, Discover and AMEX accepted

Electronic Servicing & Technology
25 Newbridge Road, Hicksville, NY 11801 516-681-2922

For Faster Service FAX 516-681-2926

A new twist to an old problem: Modern vertical deflection problems

by Bob Rose

Vertical problems used to be reasonably easy to diagnose and solve. As a technician, you know that this overstates the case somewhat because a certain percentage of those problems caused you to lose both the hair on your head and your patience. For the most part, however, they have been among the easiest problems with which you and I have dealt. You put a TV on your bench and turn it on. All of a sudden, a horizontal line appears across the face of the picture tube, and you know you are dealing with a failure in the vertical deflection circuit. Simple, isn't it? And most of the time, you had the set fixed and on its way back home in relatively short order.

Examples from "the good old days"

An old saying has it, "A picture is worth a thousand words." So let's take the case of a Quasar TP1920DW. I placed the 19-inch set on my bench and turned it on. The audio came up almost immediately, but the screen remained black. I turned the G2 voltage up slightly and saw that familiar white horizontal line that ran from the left to the right of the screen shouting that vertical drive had failed.

I try to use a systematic approach to solving problems even if the problems appear to be simple (I should say, "Especially when they seem to be simple."). So, after fishing Photofact 2728-1 for the TP1920 out of the filing cabinet, I measured the voltage at each pin of IC451 (Figure 1). Voltage checks are almost always the number one item on a troubleshooter's list. I have violated that rule more than once and lived to gripe

Rose is an independent consumer electronics business owner and technician.

AN5521					
4	1.0V	IC451 VERT OUTPUT	13.5V	2	
	0.05V		26.6V	0.9V	
	5	7	1	3	6

Figure 1. All of the AC voltages on IC451 were off. Replacement of the jungle IC with an exact manufacturer's replacement, AK5301VK, restored vertical deflection to this Quasar TP1920DW.

about my loss of "common sense." Ever replace a fairly expensive integrated circuit because you just knew it was bad, only to find out that it didn't work because a one-cent resistor had opened? Well, all of the ac voltages on IC451 were off, including the one at pin 4. Since I use an oscilloscope with a DMM readout for troubleshooting, I noted when I measured the voltage at pin 4 that there was no vertical drive.

I switched the focus of my troubleshooting from IC451, the vertical output IC, to the "jungle IC." I had the requisite B+ voltages, but the ac voltages associated with vertical deflection

were considerably off. Assuming that lack of drive was the cause of absence of vertical deflection, I replaced the jungle IC with an original AK5301VK and was gratified with the results when I turned the set on and it worked.

Another example of the way it was

Let's use Quasar model TS2523EK as another example of the way "things used to be." The customer said he turned the TV on one morning, heard the sound, but just had a white line across the center of the screen instead of a picture. It didn't take long to confirm the symptom.

Troubleshooting goes far easier if you have decent literature. Even though I have factory service information, I usually prefer to work with a Photofact. I have gotten accustomed to the way they are laid out and find them, and this is a generalization, usually easier to read than most of the factory literature with which I work. So, I got Photofact 2833-2 and went to work.

Here's what I found. There was no sign of B+ at pins 7 and 12 of IC 451

Table 1.

- pin 1 V_{cc} (usually on the order of +12V)
- pin 2 vertical trigger in (vertical pulse from "jungle" IC)
- pin 3 ramp generator in
- pin 4 vertical size in (pin may be grounded)
- pin 5 ramp generator out (develops vertical ramp)
- pin 6 vertical drive in
- pin 7 V_{cc} (usually on the order of +26V)
- pin 8 pump up (voltage here ensures quick retrace)
- pin 9 feedback
- pin 10 ground
- pin 11 vertical drive output to the yoke
- pin 12 V_{cc} for vertical output transistors (about +26V)
- pin 13 ramp wave generator

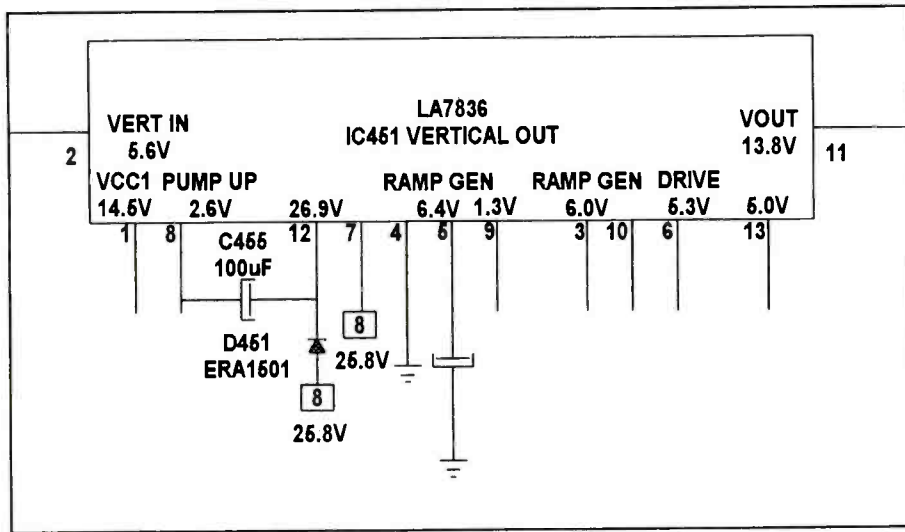

Figure 2. There was no sign of B+ at pins 7 and 12 of IC 451 in a Quasar model TS2523EK, which exhibited the symptom of failure of the vertical deflection.

(Figure 2). I traced the problem to an open R552 in the +26V line which is designated as voltage source 8 on the Photofact (Figure 3). Being a suspicious fellow, I measured the resistance between pin 7 of IC451 and ground and found it to be low, which of course indicated a short on the line. To be safe, I replaced R552, D552, C566, and IC451. Replacing all of the parts might have been "overkill," but it is better to be safe than risk a callback that wastes time, parts, and money. Besides, those parts are inexpensive. Why be pennywise and dollar foolish?

More about IC451

IC451 belongs to the popular LA78XX series of vertical output IC's. The exact part number on the IC depends on the screen size, but the pinout remains unchanged (Table 1).

In my various readings, I stumbled across an internal diagram of a typical LAXX chip and thought you might like to take a peek at it (Figure 4). This particular one reproduces the insides of a LA7838 from the perspective of a Sharp engineer. Go back to Figure 2 for just a moment and pay attention to the components tied to pins 8 and 12.

Any vertical deflection scheme has to make arrangements for rapid retrace, that is the rapid movement of the electron beam from the bottom to the top of the screen. The LA78XX series of IC's makes use of a "voltage doubler circuit" to increase the voltage to almost twice the normal run B+ to ensure rapid, smooth retrace. The circuit uses D451 and C455 to develop the voltage. If you have done much work on these circuits, you know that C455 often causes trouble ranging from reduced vertical height, to reduced vertical height with compressed

picture and retrace lines, to complete loss of vertical deflection.

Troubleshooting the LA78XX-based vertical circuits

Fortunately, these circuits are relative-ly easy to troubleshoot because you can pinpoint most problems simply by taking a few voltage measurements. For example, absence of B+ at pin 12 while it is present at pin 7 indicates an open D451 (Figure 2). A voltage higher than 6.4V at pin indicates that C452 either has failed or is in the process of failing. By the way, C452 can cause symptoms that range from reduced deflection to no deflection at all. It is notorious for failing in the early Sanyo-Fisher TVs. I see that Sanyo-Fisher has begun to use tantalum capacitors in place of the aluminum electrolytics. I suppose the change is due to the frequent failure of the 1µF aluminum electrolytic capacitor.

I think I have said enough for you to get the point. Voltage and waveform measurements permit you to put your finger on a vertical deflection problem in relatively short order. I certainly recommend using an oscilloscope as you search for the problem, especially one that combines ac voltage and waveform analysis at the same time. I have also found an ESR meter to be a valuable tool as well, because it locates those dry capacitors without your having to take them out of circuit to identify them.

One more example of older vertical circuits

I will burden you with one more example before moving on to the newer stuff. This one concerns a Toshiba CF1920A. When I put it on my bench and turned it on, I saw a peculiar pattern

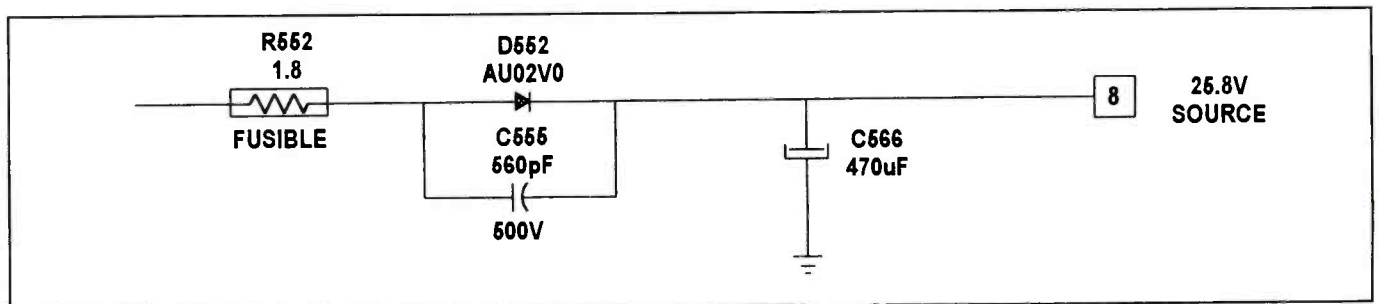

Figure 3. An open R552 in the +26V line of this Quasar model TS2523EK was the cause of failure of vertical deflection. Replacement of that component, and several other suspect components, restored the set to operation, and assured a long-term fix.

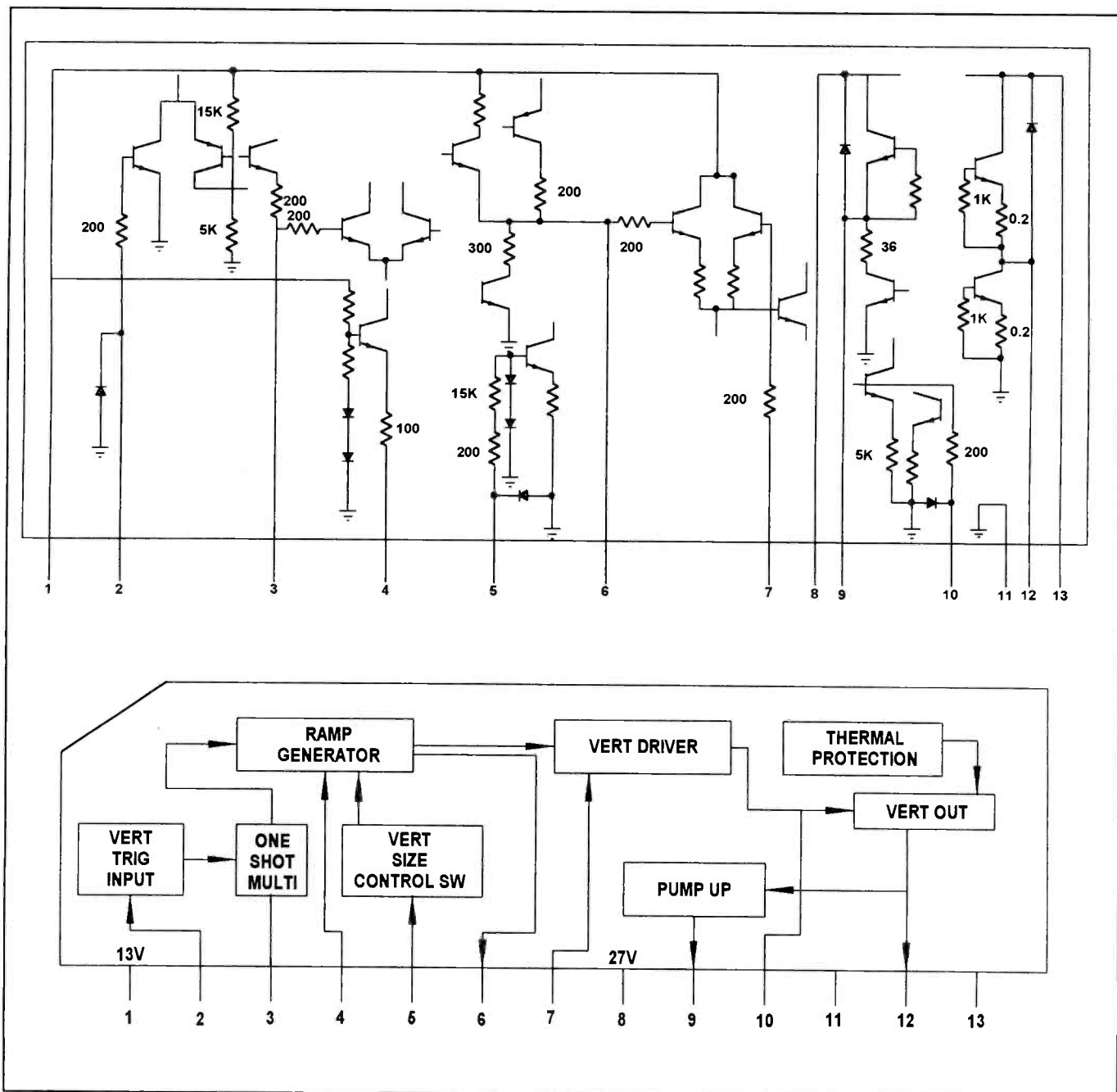

Figure 4. The LA78XX series of vertical output ICs (of which IC451 in the Quasar TS2523EK is an example) is used in a number of TV sets. The exact part number depends on the screen size, but the pinout remains unchanged. This particular one reproduces the insides of an LA78388 from the perspective of a Sharp engineer.

appear on the screen. The bottom half was dark while the top half was filled with retrace lines. I referred to Photofact 2950 (Figure 5) to see how Toshiba had configured the circuit and had a hunch we servicemen often get. I can't explain those hunches, or flights of intuition, but I have learned to trust them. A little voice inside me kept saying, "Look for a failing electrolytic."

I reached for my ESR meter and began checking capacitors. However,

the capacitors located around IC301 checked good. I spied C301 in the schematic and when I checked it, I saw that it had begun to dry out. Replacing it fixed this 19-inch set. Capacitor C301 is easy to overlook because it is located very near IC501.

How vertical problems show up today

Most major manufacturers of modern televisions have added a circuit that monitors vertical deflection and turns

the set off when it fails. Two trends have spurred the use of the so-called "CRT protection" circuit.

First, consumers are buying more large-screen and very-large-screen TV sets. I am seeing far fewer televisions under 25 inches than I have ever seen, but I am seeing more 27 inch and larger ones than I have ever seen. Did you ever imagine that you would think of a 27 inch TV as "a small-screen TV"? Well, folks, it's that way today.

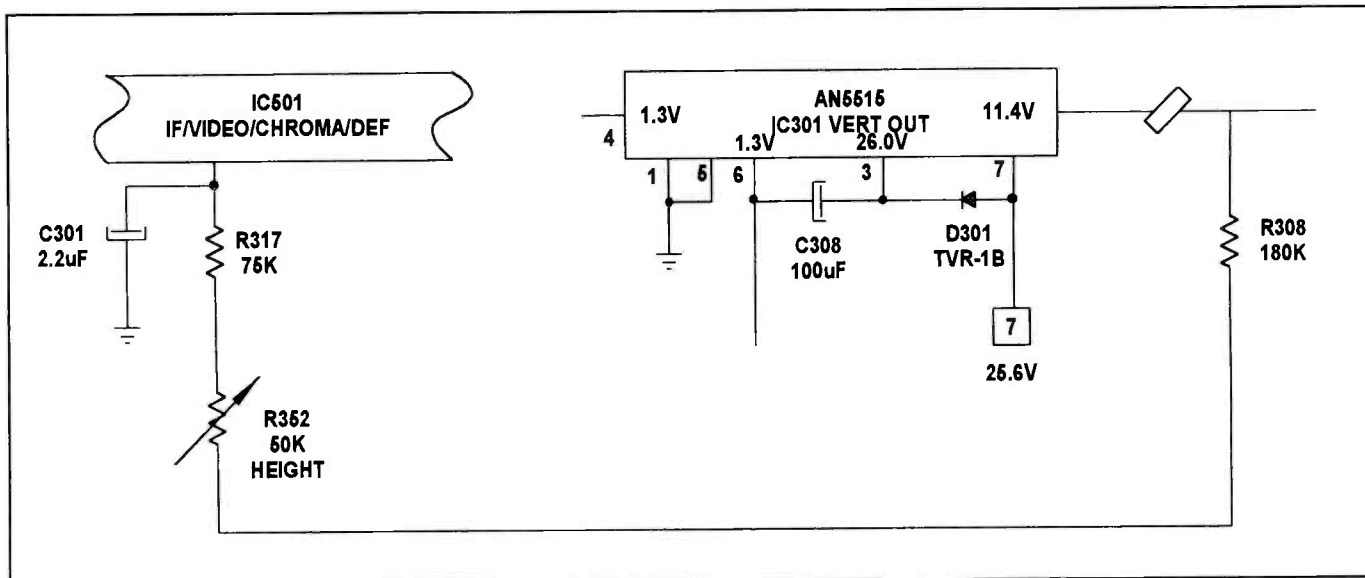

Figure 5. The bottom half of the screen of this Toshiba CF1920A was dark while the top half was filled with retrace lines. A check of capacitor C301 using an ESR meter showed that it has begun to dry 21 out. Replacement of C301 restored the screen to normal.

The picture tubes for the larger sets are quite expensive, often costing in excess of a thousand dollars. Imagine what happens when vertical deflection fails and the user continues to use the TV just because, "I can still hear it." You guessed it, the electron beam burns the phosphor in the very center of the screen. I serviced a 27-inch Zenith just yesterday that had a light phosphor burn across the screen. The line was visible when the TV was off but fortunately

couldn't be seen when it was on. It was therefore inevitable that smart manufacturers come up with a way to protect those expensive large and very-large picture tubes from damage.

Second, the ubiquitous use of microprocessors provided a quick solution with respect to configuring a protection circuit. An engineer could use a handful of inexpensive components to feed a voltage to a certain input of the microprocessor, have that chip monitor the

voltage, and turn the set off if the voltage dropped below a certain level. And that is exactly what has happened.

A vertical problem in a Hitachi 27CX7B

The owner brought this set in for repair complaining that it wouldn't stay on. I live and work in an area of the country where Hitachi products are not widely used, meaning that I am not as familiar with them as I am with the pop-

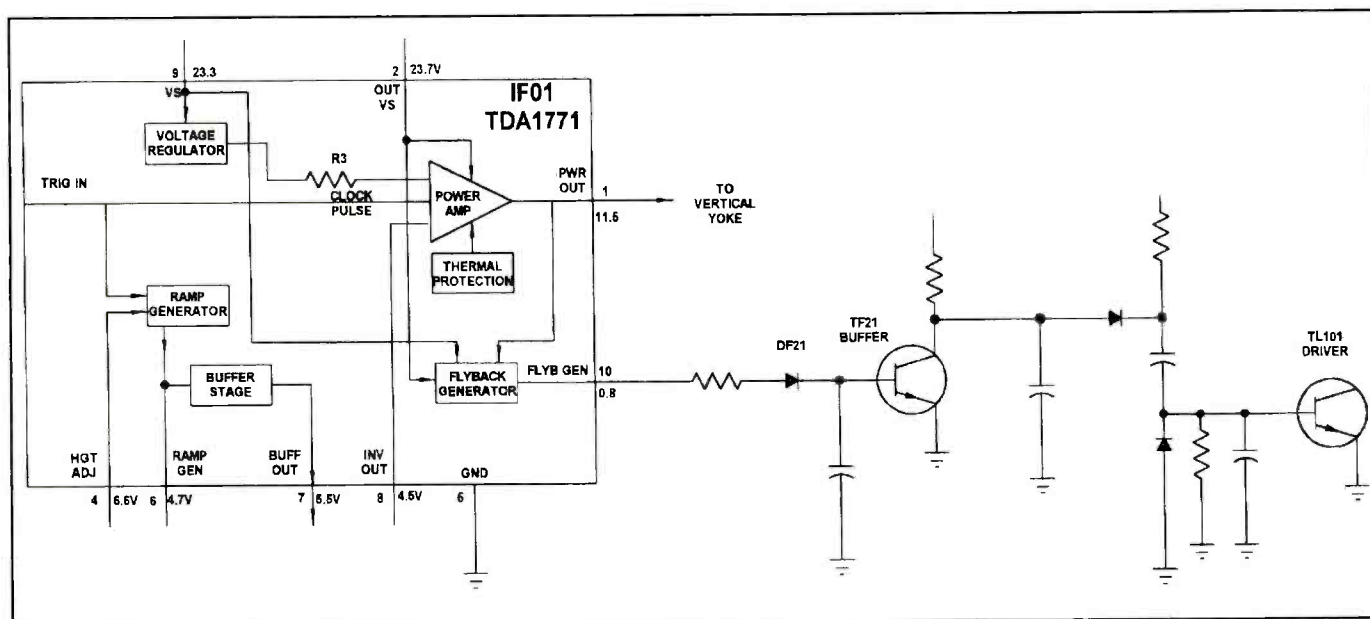

Figure 6. I was faced with an RCA T1960GY combi that had no vertical deflection. In this set, vertical drive exits pin 1 of IF01 and goes to the vertical yoke. Horizontal drive exits at pin 10, goes to TF21, configured as a buffer transistor, and on to the horizontal driver transistor (TL01). In this set, a shorted IF01 caused the unit to lose the +24V supply, which caused the horizontal drive to stop, and the set to shut down.

ular products, but we are authorized to service them under warranty. After confirming the owner's complaint, I pulled the literature and waded through the jumble of lines and figures that greeted me. I confirmed the operation of the power supplies, horizontal deflection, and the fact that the XRP circuit wasn't the culprit. "What now," I wondered?

I happened to see the legend "protect in" beside pin 8 of the microprocessor and an alarm went off in my head. According to the literature, pin 8 ought have about +5V on it, but it registered 0V. Looking at the schematic, I saw that the system developed the +5V from the +26V and used it monitor the status of +26V line. Was the problem caused by a failure of the +26V or one or more of the components in the monitoring circuit? When I applied +5V from an external ac supply, the TV came on but without vertical deflection. I moved the probe of my scope to pin 7 of the vertical output IC looking for about +26V and found nothing. The schematic showed that the +26V was developed by a pulse taken from pin 6 of the IFT. It also showed a pico fuse in the line. The voltage was present on the IFT side of the pico fuse but not on the side going to I601. The fuse had opened. A quick resistance check told me I601, C711, and D713 seemed to be okay. I replaced the fuse, and the TV began to hum like a new one.

A vertical problem in an RCA T1960GY Combi

RCA uses a different circuit to achieve the same results in its T1960GY combi. I won't reproduce the entire schematic because it is lengthy and involves far more circuits than we need to consider, but I do include the circuit(s) that develop vertical and horizontal drive (Figure 6). Vertical drive exits pin 1 of IF01 and goes to the vertical yoke. Horizontal drive exits at pin 10, goes to TF21, configured as a buffer transistor, and on to the horizontal driver transistor (TL01). If the unit loses the +24V supply for any reason, like a shorted IF01, horizontal drive stops, and the unit shuts down.

A vertical problem in a Zenith A Line

Starting with its Y-Line series, Zenith began using a protection circuit and has produced several variations of it

between then and now. In some instances, like the Y-Line and the brand-new B-Line, the microprocessor looks for approximately +5V at one of its pins. If the voltage is absent, the microprocessor assumes vertical deflection has failed and shuts the TV down.

You may be a step or two ahead of me by realizing the failure could be either in vertical deflection or the circuit that develops the ac voltage and applies it to the microprocessor. Fortunately, finding the problem is relatively easy. If the +5V is absent, merely substitute it by using an external power supply or by using a small value resistor and connecting the relevant pin of the microprocessor to the standby +5V line. Zenith service recommends the latter approach when you service the new B-Line products. Be certain that you turn the G2 control down as you proceed with your troubleshooting to keep from damaging the picture tube.

The A-Line televisions do it a bit differently. As you may know, the A-Line consists of the GA-1, GA-2, and GA-3 chassis. I sort of closed my eyes and reached for a manual, coming up with the one for the GA chassis. The service manual says that if the power supply works and the set goes into shutdown, the servicer must check two circuits. Shutdown, by the way, means that when the set turns off it cannot be turned back on until the microprocessor has been reset by unplugging it from the ac line. The two circuits to check are x-ray protection and vertical sweep CRT protection. The former activates about 1.6 seconds after the set turns on while the latter activates something like 3 seconds after turn on.

If you can't tell the difference between 1.6 seconds and 3 seconds, and who can, look at the voltage on pin 29 of the video processor IC (ICX2200). If the voltage reaches 3.5V ac, the TV will shut down. You may defeat x-ray protection by lifting DX3005 in the GA-1 chassis, but don't defeat the circuit unless you absolutely know what you are doing. If the shutdown isn't XRP related, turn your attention to the CRT protection circuit by looking for vertical pulses at pin two of the microprocessor.

Turning on the set with the video output board removed

Permit me to digress for just a minute. Zenith has added a new feature to its

19/20-inch GA-1 chassis. R3212 is used both in the CRT heater and XRP circuits. If you attempt to turn the set on with the CRT board removed, the voltage at pin 29 of ICX220 (the video processor) will go high and activate the x-ray protection circuit. If you need to test the TV with the video output board removed, connect a 9Ω, 5%, 10W resistor between pins 9 and 10 of the CRT socket. The TV will now stay on and permit you to make whatever tests you need to make.

I could add illustration upon illustration to demonstrate that many modern television receivers use circuits that shut the receiver down when vertical deflection fails. I haven't, for example, even mentioned Philips' products like the A-8, the B7/B8, and the newer D7 chassis. But the few that I have mentioned should be sufficient.

Vertical protection circuits aren't new

Vertical protection circuits really aren't new because they have been used in projection sets for years, and variations of them have even been around in certain direct view sets. For instance, I fixed a Magnavox T-1 chassis a few weeks ago that went into shutdown almost immediately at turn on. Since I knew the problem wasn't x-ray related, I lifted one of the transistors in the shutdown latch and discovered that vertical deflection had failed. In this instance, though, a failed vertical deflection circuit actually activated the beam limiter circuit that turned on the shutdown latch. The details of the circuit aren't obvious when you study the schematic because the circuits that do the work are internal to the video processing integrated circuit. At least, that is the information I got from one of Philips' technical engineers.

But vertical protection circuits are new in that we servicers are finding them for the first time in abundance in direct view sets. Since the circuits are relatively new, you may be fooled the first time or two you encounter a shutdown problem and can't find what is causing it. May I suggest you put a mental red flag in your "memory bank" and permit it to wave a few times to remind you that vertical problems now lead to shutdown problems.

Good servicing! ■

Products

High current dc regulated power supplies

Extech's analog dc power supplies, Model 382222 and Model 382225, display output voltage and current. Model 382222 supplies up to 12A dc current output and Model 382225 supplies 25A. Bindings post output terminals accept banana plugs or bare wires. Easy snap terminals are available for low current requirements. Both models feature an LED overload indicator, built-in forced air-cooling fan, and overload and short circuit protection.

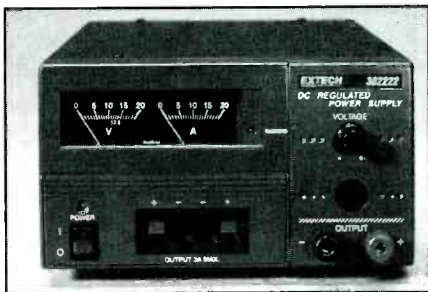

Extech Instruments, 335 Bear Hill Road, Waltham, MA 02451.
Phone: 781-890-7440, Fax: 781-890-7864, E-mail: extech@extech.com,
Website: www.extech.com

Circle (106) on Reply Card

Data acquisition system for MS-Windows™

In addition to standard measurement function (AC/DC voltage/current, resistance, frequency, capacitance and temperature), this 3-1/2 digit, 1999 count DMM from Hub Material Company features a built-in RS-232 serial interface plus data acquisition software which runs under MS-Windows™. Simply cable the DMM to any available serial port on the PC, select the measurement you wish to monitor, and attach the test leads to the device being monitored. The software lets users set up timing sequences for automatically collecting data, multiple windows (analog meter, graph, digital display, data list), and audible Hi/Lo alarms. Data collected is displayed on the PC and can be saved as a graphic or ASCII file, which can be brought into Lotus or Excel spreadsheets, or other graphing and data presentation programs.

Other features include an analog bargraph, audible continuity beeper, diode test, transistor hFE test, min/max/avg recording, relative measurement, data hold, and overload warning. Comes with instructions, 9V battery, test leads, K-type temperature probe, software, RS-232 serial cable terminated with a standard DB9F connector, and carrying case. An optional datalogger module can be used with the DMM to store approximately 1800 readings using its built-in 32K RAM. You can configure the module to capture readings at the time intervals from 1 to 600 seconds (10 minutes). Stored readings can later be transferred from the datalogger's RS-232 port to your PC using any communications program. Optional adapters are available for measurement of AC/DC clamp-on current, light level, temperature, humidity, airflow and RPMs.

Hub Material Company, 33 Springdale Avenue, Canton, MA 02021

Circle (107) on Reply Card

Cordless soldering iron

BS Manufacturing announces the P100, a cordless soldering iron that provides precision heating power in the form of a tiny pen-style tool that is 19cm/7.5 inches long. The tool delivers up to 120W output, allowing it to be used for heavy duty electrical work and silver soldering, in addition to precision electronics and model making applications. The new iron can be purchased online at www.vulkangt.com or distributors.

The tool is useful for mobile installation, repair and maintenance personnel, and any factory staff that needs mobility. It enables technicians working away from electrical power sources, or in different circumstances such as restricted spaces, to achieve high productivity.

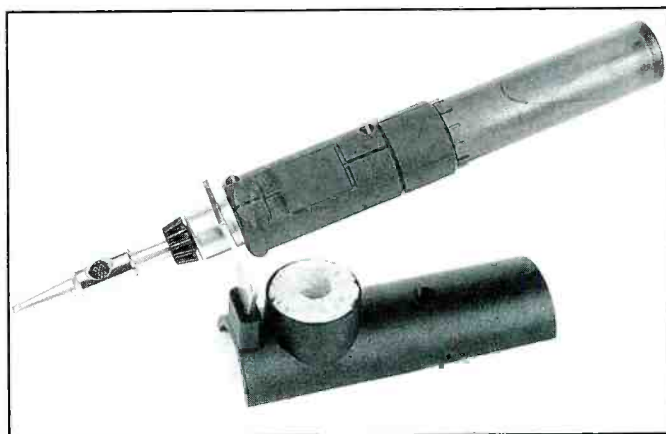

The iron utilizes catalytic conversion for the majority of its application configurations, delivering heat to the tip by means of infrared radiation. The fuel is liquid/butane/propane gas, stored in the translucent handle of the tool in a similar fashion to a disposable cigarette lighter. This tank is refilled with a squirt from a gas canister — a low-cost consumer item in use around the world. Each refill provides around 45 minutes of continuous use at a typical setting.

BS Manufacturing, Strawhall Industrial Estate, Carlow, Ireland,
Phone: +353-0-503-41340, Fax: +353-0-503-40363, E-mail: sales@vulkangt.com

Circle (108) on Reply Card

Network cable testers

BK Precision announces the addition of two new low-cost network cable testers, the Model 230 Multi-Network Cable Tester and the Model 231 Deluxe Multi-Network Cable Tester.

The Model 230 is a portable, battery-powered, stand-alone network cable tester that can be used for testing most popular network cables such as thin Ethernet (BNC), 10Base T (UTP/STP), 100BaseTx, RJ45, 356AS, TIA-568A, and Token Ring cables. The unit also tests the ground of shielded twisted pair cables. The accompanying remote unit allows the user to remotely test installed cable either from the wall plate or patch panel.

The Model 231 is a portable, battery-powered, stand-alone network cable tester that can be used to easily read the correct pin configuration of 10Base T cable (category 5), 100BaseTx,



10Base2 cable (coax) and RJ45/RJ11 modular cables, TIA-568A, TIA-568B, and Token Ring cables by comparing one transmitting end to the corresponding receiving end. It tests point-to-point rather than pair-to-pair. By utilizing the supplied remote kit, the Model 231 can test cables installed as far away as 1,000 feet, either on a wall plate or patch panel.

B&K Precision, 1031 Segovia Circle, Placentia, CA 92870-7137, Phone: 714-237-9220, Fax: 714-237-9214, Website: www.bkprecision.com

Circle (109) on Reply Card

Newly designed magnifier

Edroy Products introduces a new design for its popular magnifier. The Millennium MAGNI-FOCUSER will feature a streamlined appearance and lighter lenses and lens plates.

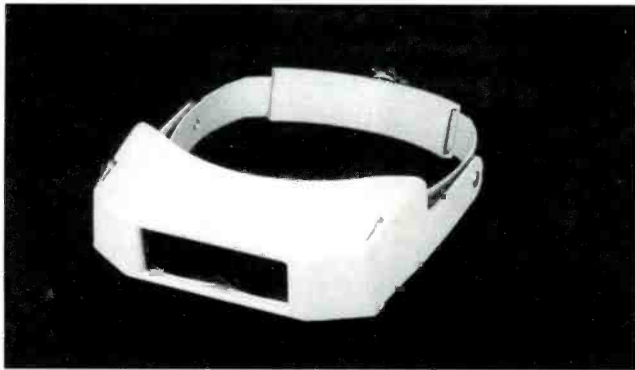

The product is available with or without a light and a bifocal lens. It features an adjustable, contoured padded vinyl headband that guarantees a perfect fit for everyone. The unit is lightweight and washable and can be worn over glasses. Its high-impact, non-corrosive ABS plastic front lens unit is both shatter proof and scratch resistant. Absence of a center post ensures that the user's field of vision is never obstructed. The new, lighter design promises to make it more comfortable.

Edroy Products, 245 N. Midland Avenue, Nyack, NY 10960. Phone: 800-233-8803, Fax: 914-358-4098

Circle (110) on Reply Card

Color analyzer update software

Sencore's CR288 PC-based color analyzer lets the technician quickly and accurately test and white balance align digital televisions (DTV), home theater direct view and projection sys-

tems, video walls, broadcast monitors, medical monitors, and high-resolution computer monitors.

The product has an easy-to-use Windows GUI, giving four options for displaying measured data, a CIE chromaticity diagram, large CIE coordinates, RGB levels, and the AutoColorPro II control window. Measurements are sync-locked to automatically read and supply the refresh rate of the display under test. The analyzer uses industry standard measurement units and display modes. Readings are displayed in Yxy, RGB, and color temperature in degrees Kelvin. Luminance units are selectable between foot-lamberts and cd/m^2 (nits). References may be entered and stored by the user, and limited only by the amount of memory available on the host system. The unit is laboratory accurate and has the specs necessary to do a complete white-balance alignment, so you can be sure you match display manufacturer specifications. Tracking data is made easy with the CR288. Print analysis data straight from the measurement screen. The printed form will contain the manufacturer's name, model number, serial number, and measured data.

Sencore, 3200 Sencore Drive, Sioux Falls, SD 57107. Phone: 1-800-SENCORE. Website: www.sencore.com

Circle (111) on Reply Card

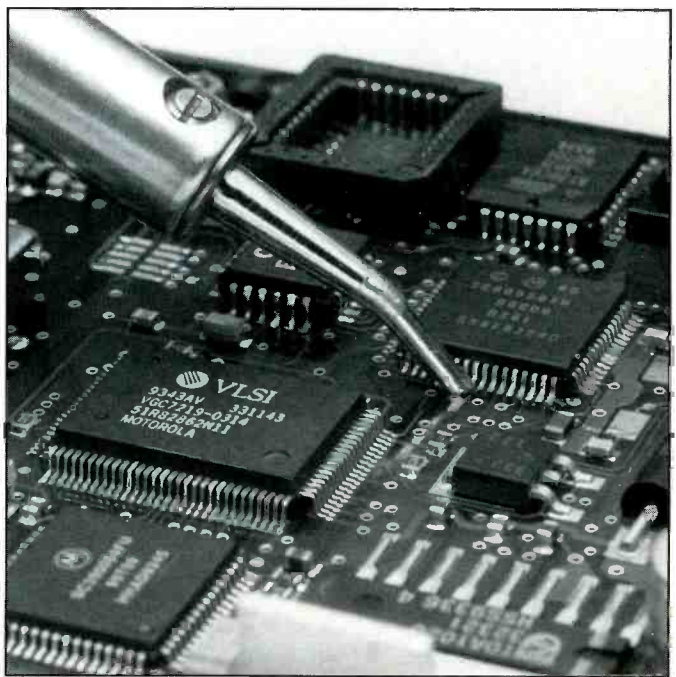

Long-life soldering tips

PACE introduces long-life soldering tips, designed to meet the demands of high production users. These tips deliver up to three times the life of conventional tips. They are manufactured from oxygen free copper and high quality iron and have a highly polished, consistent finish. A wide selection of 22 long-life tips available for the PS-80 soldering iron allow the production user to successfully solder virtually any thru-hole or surface mount assembly.

PACE, 9893 Brewers Court, Laurel, MD 20723-1990. Phone: 301-490-9860. Fax: 301-604-8782. Website: www.paceusa.com

Circle (112) on Reply Card



Fiber adapter kit

With the new OMNIFiber Adapter Set from Microset, available from Jensen Tools, you can now test single and multimode fiber. Press the "Autotest" button to measure length, loss, and propagation delay on both transmit and receive fibers at 850 and 130nm simultaneously. The set then compares the results to the appropriate industry standard and provides a simple pass/fail indication of the tested link. With singlemode fiber, it measures loss on transmit and receive fibers at 1310nm.

The product includes two adapters, a companion CD, two 1M 62.5/125 dual multimode cables, two ST-style coupling sleeves, optic cleaning pads, user documentation and a carrying case.

Jensen Tools, 7815 S. 46th Street, Phoenix, AZ 85044. Phone: 800-426-1194, Fax: 800-366-9662, Website: <http://www.jensentools.com>

Circle (13) on Reply Card

Illuminated ring magnifier

Waldmann Lighting's RLLE-122 ring magnification task light now offers a permanent 5-diopter quality magnification lens for increased magnification. This new illuminated magnifier also offers an electronic ballast, built-in arm for enhanced efficiency.

The unit is useful for conventional assembly, inspection, and soldering applications. A longer 24-inch top arm which extends to 43.5 inches is available for larger work areas and is ideal for production benches and workstations.

The magnifier lamp also offers a 4d (2x) "drop-in" Add-X lens which increases the light's power to 9d (3.25X). A lens

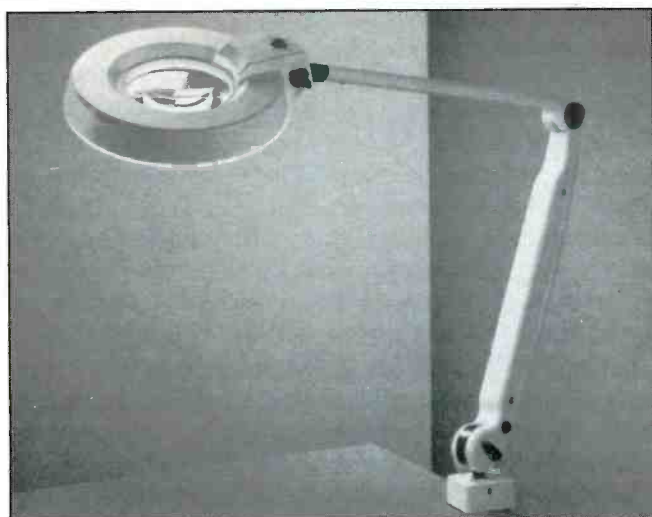

cover which protects against dust and scratches, and an industrial-grade clamp are both included.

A 22W circline lamp provides even light distribution to the work surface and 12,000 hours of life. An optional UV lamp is available for laboratory applications requiring black lights.

Waldmann Lighting, 9 West Century Drive, Wheeling, IL 60090, Phone: 800-634-0007, Fax: 847-520-1730, Website: www.waldmannlighting.com, E-mail: waldmann@enteract.com

Circle (114) on Reply Card



Soldering station

Weller, a Cooper Tools brand, offers the WES50, a soldering station that features a new heater and sensor combination that allows for relatively quick heat up and recovery. The station itself utilizes a cordless method to provide temperature lockout and tip temperature calibration. The station also has an automatic shut-off feature after 99 minutes of inactivity to extend tip, iron, and station life. The product is ESD safe.

Cooper Tools, Lufkin Road, P.O. Box 728, Apex, NC 27502, Phone: 919-362-1670

Circle (115) on Reply Card

Electronic soldering station

Elenco Electronics announces the latest to its lines of soldering products: the SL-5 Soldering Station.

It is electronically controlled to provide 5W to 40W or 60W and is ideal for professionals, students, and hobbyists. The unit includes a holder funnel for the iron, sponge pad for cleaning the tip and an on/off indicator light.

A special safety feature of the SL-5 is its ground fault detection circuit, which warns you if your station is not properly connected to the earth ground, if your hot and ground wires are reversed. This is important when working with today's static-sensitive electronic components and is critical when working with high-voltage circuitry. It can also detect problems in the electrical outlet it is connected to.

The ground fault safety circuit turns on when the following problems are present at the power source: open ground, hot and ground reversed, hot and neutral reversed. The unit has a cushion grip handle with grounded tip for soldering static-sensitive devices and uses long-life plated conical tip.

Elenco Electronics, 150 W. Carpenter Avenue, Wheeling, IL 60090, Phone: 847-541-3800, Fax: 847-520-0085, Website: www.elenco.com

Circle (116) on Reply Card

What's Your Best Servicing Value? The magazine that makes money for you!

THE PROFESSIONAL MAGAZINE FOR ELECTRONICS AND COMPUTER SERVICING

ELECTRONIC

Servicing & Technology



As an electronic servicing professional, it's crucial for you to keep current in an industry that's always growing and changing.

Each month, **ES&T** brings you how-to service articles on TVs...VCRs... Computers... CD players...Microwave ovens...Audio products and more. It's the information you need to do your job every day.

Regular columns and special features from experts will make you more efficient – and more profitable – in no time. Plus, our monthly PROFAX, a FREE 8-page pull-out of popular TV, VCR and computer schematics, makes **ES&T**

an even greater value.

Subscribe today to the only magazine devoted to you!

SUBSCRIBE TODAY!!

United States

1-yr (12 issues)\$26.95
2-years (24 issues)\$49.95

Canada/Mexico

1-yr (12 issues)\$36.95
2-years (24 issues)\$69.95

Foreign Air Post

1-yr (12 issues)\$44.95
2-years (24 issues)\$85.95

When ordering include: Name, address, city, state, zip. Check, money order, MasterCard, VISA, Discover, and American Express accepted. Send credit card number along with expiration date. If renewing, send a label along with your request.

Send all Subscription requests to:
Electronic Servicing & Technology

25 Newbridge Road

Hicksville, NY 11801

Ph: 516-681-2922 FAX: 516-681-2926

Literature

(Continued from page 3)

plugs, spacers/standoffs, and many more. A cross-referenced table of contents helps find items of interest more quickly. The catalog is also available on-line, in PDF format, on the company's website at www.keyelco.com.

The catalog is illustrated with detailed drawings, specifications, and photographs along with application information. Also summarized are the company's manufacturing capabilities such as precision tool and die making, custom stamping, machining and assembly, and the ability to provide products that meet virtually any custom requirement.

Keystone Electronics Corp., 31-07 20th Road, Astoria, NY 11105-2017, Phone: 800-221-5510, Fax: 718-956-9040, E-mail: kcc@keyelco.com, Website: keyelco.com
Circle (102) on Reply Card



Telecom catalog

Jensen Tools has released a catalog designed especially for the telecom, electrical, and global communications industries. This 116-page, full-color catalog offers a wide range of tool kits, hand and specialty tools, cable, telephone and electrical test equipment and service aids. Many new products are featured including the company's new line of JTS Telecom Test Sets.

Jensen Tools, 7815 South 46th Street, Phoenix, AZ 85044, Phone: 800-426-1194, Fax: 800-366-9662, E-mail: jensen@stanleyworks.com, Website: www.jensentools.com
Circle (103) on Reply Card

CD answers power measurement questions

LeCroy Corporation has released a new CD that contains "everything an engineer needs to know about making power measurements." The CD contains vital information on how to measure a variety of parameters, including device turn-on and turn-off power losses, conduction losses, safe operating area, dynamic on-resistance, control loop stability to line and load changes, power factor, and current harmonics for a wide range of power supply applications. Engineers working on switchmode power supplies will find the CD very helpful.

Developed as a resource for engineers who must conduct power measurements, the CD explains how to perform power device analysis, modulation analysis, and line power analysis. A series of tutorials, each addressing a specific application, thoroughly describe the instruments necessary and procedures used to conduct highly accurate power measurements. Also on the CD is an hour-long interactive presentation on power measurement techniques, including a Q&A session.

LeCroy Corporation, 700 Chestnut Ridge Road, NY 10977-6499, Phone: 914-425-2000, E-mail: contact.corp@lecroy.com, Website: <http://www.lecroy.com>
Circle (104) on Reply Card

Components catalog

Jameco Electronics announces their latest catalog 201 "The Face of Innovation." This 150 page catalog features thousands of ICs, components, tools, test equipment and computer products for OEMs, engineers, educators and service/repair technicians. More than 250 new products have been added, including new lines of security camera equipment, toroidal transformers, and fiber optics. The company has also expanded lines of power supplies, motors, soldering equipment, basic controller chips and peripherals.

Jameco Electronics, 1355 Shoreway Road, Belmont, CA 94002, Phone: 650-592-8097, Fax: 650-592-2503, E-mail: info@jameco.com, Website: www.jameco.com
Circle (105) on Reply Card

Classified

Classified advertising is available by the word or per column inch.

By-the word. \$1.65 per word, per insertion, pre-paid Minimum charge is \$35 per insertion. Initials and abbreviations count as full words. Indicate free category heading (For Sale, Business Opportunities, Miscellaneous, Wanted). Blind ads (replies sent to ES&T for forwarding) are \$40 additional. No agency discounts are allowed for classified advertising by the word. Contact Alycia NicholSEN at 516-681-2922 to place your classified ad (by-the-word). Mastercard, VISA, American Express and Discover are accepted for FAX or mail orders.

Per column Inch (classified Display): \$235 per column inch, per insertion, with frequency discounts available, 1" minimum, billed at 1/4" increments after that 10" maximum per ad. Blind ads are \$40 addition. Reader Service Number \$25 additional to cover processing and handling costs. (Free to 4-inch or larger ads.) For more information regarding classified display advertising, please call 630-584-5333. Optional color (determined by magazine) \$150 additional per insertion.

Electronic Servicing & Technology
25 Newbridge Rd, Hicksville, NY 11801 Attn: Classified Department
Ph: 516-681-2922 FAX: 516-681-2926

FOR SALE

TEST EQUIPMENT FOR SALE: REASONABLE PRICES SENCORE, TEKTRONIX, HP and MUCH MORE. View complete list at: <http://www.astglobal.com> or contact: **AST GLOBAL ELECTRONICS.** Voice: 888-216-7159; Fax 814-398-1176; e-mail: sales@astglobal.com

All Consumer VHF Drop In Power Supplies Rebuilt, \$29.95. Commercial supplies please call. Free Shipping. Liberty Electronics, 207 W. Clinton Avenue, Oaklyn, NJ 08107. 856-854-4443. E-mail jkliberty@aol.com

WinSTIPS! — 142,000 Current tips from 500 shops! All brands. \$149.95. ServiceTalk E-mail repair group \$59.95/yr. WinSERVService Management software \$299.95. <http://www.ServiceSoftware.com>. KDTV 514 3rd St., Aurora, IN 47001. 1-888-537-8477. All c/cards. Download software run FREE 30 days.

FURTHER PRICE REDUCTION. Diehl Mark III \$49, Diehl Mark V Horizontal circuit tester \$169. New. Conductive coating for remote control keypads \$9.99 ppd. **WEEC**, 2411 Nob Hill Road, Madison, WI 53713. 608-238-4629, 608-273-8585.

SENCORE, TEKTRONIX, HEWLETT PACKARD (all models). We **BUY, SELL, & TRADE.** Please call "CHOICE ELECTRONICS" for all of your test equipment needs. Complete financing options available. Call 1-800-609-0677, 605-361-6386 ask for Lance Tople.

*******NAP Tuner 340309******* RCA Tuner TCHRIA or TCCRIA and more. Snowy picture? **Will rebuild for \$25.00, Free Shipping!!! Tip Top TV & VCR**, 18441 Sherman Way, Reseda, CA 91335, 818-345-1974.

****FREE** Service Tips for TV's, VCR's, Projection TV's, CAM-CORDER's.** Must have IBM compatible computer. Send your Name and Address to: **FREE SERVICE TIPS, P.O. BOX 464, WHEATLEY HEIGHTS, NY 11798.**

SPECTRUM ANALYZERS, new B&K 500 MHz, \$1,150.00. 16 Hz \$1,800.00. Full line of new and used electronics test instruments. Free catalog. GEOMA (608) 462-4222.

FOR SALE

TV CASE HISTORIES: Volume 8 with 3,325+ histories. Satisfaction assured. Only \$59.75 (plus \$3.25 shipping). Over 10,100 books and supplements sold with only 1 returned for a refund! **Mike's Repair Service**, P.O. Box 217, Aberdeen Proving Ground, MD 21005. Same mailing address 36+ years. Send SASE for samples. 410-272-4984, 1-800-2-FIX-TV 11a.m.-9 p.m. (<http://mikesrs.webjump.com>)

Sencore CM2125 Computer Monitor Analyzer, \$2195.00. CR70 CRT Analyzer, \$595.00. PF57 Isolation Transformer, \$295.00. VC93 VCR Analyzer, \$275.00. Tektronix 465B 100 MHz Oscilloscope, \$295.00. VS-108 8-monitor Signal Expander, \$125.00. Monitor Wizard Monitor Analyzer, \$125.00. LPM-5673 Laser Power Meter, \$65.00. 72-960 LCR Meter, \$75.00. Capacitor Wizard, \$75.00. Visa, Mastercard and Discover Accepted. Contact: 303-475-1582.

IN-CIRCUIT CAPACITOR TESTER — Find bad caps FAST and RELIABLY with the Capacitor Wizard in-circuit ESR Tester! Great for monitors, switching power supplies, TV, etc. Still only \$179.95. MC/VISA. **Independence Electronics Inc. 800-833-1094. www.awiz.com**

TEST EQUIPMENT BOUGHT & SOLD: OSCILLOSCOPES, ETC. 925-706-0177. FAX: 925-706-0156. www.oscilloscopesetc.com

WANTED

WANTED:USED TEST EQUIPMENT. TURN IDLE OR EXCESS EQUIPMENT INTO CASH. AST GLOBAL ELECTRONICS. Voice: 888-216-7159; Fax 814-398-1176; e-mail: sales@astglobal.com.

BUSINESS OPPORTUNITIES

CENTRAL FLORIDA TV/ELECTRONICS Business/Building. Heart of the retirement area. 36 years (75K). Owner retiring. **941-385-0359.**

Reader's Exchange

Readers' Exchange is a free service.

The following restrictions apply to Readers' Exchange:

- Only individual readers may use Readers' Exchange, and items must be restricted to those that are ordinarily associated with consumer electronics as a business or hobby. If you're in business to sell the item(s) you want to offer for sale, the appropriate place for your message is in a paid advertisement, not Readers' Exchange.
- Readers' Exchange items must be restricted to no more than three items each for wanted and for sale.
- All submissions must be typed or printed clearly!

Send your Readers' Exchange submissions to:
Readers' Exchange
Electronic Servicing & Technology
25 Newbridge Road, Hicksville, NY 11801
Phone: 516-681-2922 Fax 516-681-2926

FOR SALE

B&K cap. meter #830 with all accessories. *Contact: Frank, 727-392-0230.*

RF generator, \$25.00. Function generator, \$45.00, complete with cables. *Contact: Sidney, 510-357-3788.*

TenTel gauges, adapters, manuals and instructional tapes, complete set, \$495.00. Fluke 50 MHz scope meter, \$695.00. B&K oscilloscope Model 2160 (60 MHz), \$295.00. All in excellent condition with manuals and cables. Shipping not included. *Contact: Ray Paul, 805-987-7278.*

B&K 545 component analyzer, tests components in-circuit with no power applied, \$1450.00. *Contact: Kim Guizke, 612-869-4963.*

Sencore VC93 video analyzer, new, all probes, manual, \$1500.00. Shipping included. *Contact: Edward Lozada, 787-839-6264.*

Howard Sams Photofacts, No. 1 through 4233. Nearly complete set. Best offer. *Contact: Ken Richardson, 803-278-1040. (fax) 803-278-1064.*

Euras service tips manuals (3). RCA, Zenith and Sharp. Over 8900 tips through Oct. '96, \$39.00 or best offer. *Contact: Greg, 612-535-3833.*

WANTED

Sony VCR, 8mm, MDL EV-S550, working mechanism deck or VCR. *Contact: Bob Peters, (fax) 941-922-5282.*

Zenith 46-inch TV Model PV4661 H-5 service manual. Will buy or copy. *Contact: Bob Reeves, 7915 Royalwood, Houston, TX 77049, phone, 281-458-0417*

Advertisers' Index

Company	Page Number	Reader Service Number	Advertiser Hotline
Aven Tools.....	14	49.....	800/624-8170
Electronic Design Specialist.....	21	62.....	561/487-6103
Electronic Servicing & Tech.....	IBC	800/853-9797
Electronics Technicians Assoc....	23	61.....	800/288-3824
Electronix Corporation.....	53	63.....	937/878-9828
Herman Electronics.....	53	800/938-4376
Isct.....	44	64.....	817/921-9101
Jensen Tools.....	13	65.....	800/426-1194
Jesse Jones Industries.....	64	800/825-6690
Newnes.....	11	66.....	800/366-2665
Philips Consumer Electronics.....	IFC	58.....	800535-3715
Sams & Company, Howard.....	45	68.....	800/428-SAMS
Sencore.....	5	67.....	800/SEN CORE
Thomson Consumer Elec.....	BC	113.....	800/336-1900

We'd like to see your company listed here too. Call Jonathan Kummer at 516-681-2922 or e-mail jkummerest@aol.com to work out an advertising program tailored to suit your needs.

ORGANIZE AND PROTECT YOUR COPIES OF

Electronic Servicing & Technology

Now there's an easy way to organize and keep copies of your favorite magazine readily available for future reference.

Designed exclusively for *Electronic Servicing & Technology* by Jesse Jones Industries, these custom-made titled cases and binders provide the luxury look that makes them attractive additions to your bookshelf, desk or any location in your home or office.

Each binder/case is covered durable leather-like material; title is hot stamped in gold.

Whether you choose cases or binders, you'll have a storage system that's durable and well organized to help protect your valuable copies from damage.

Quantity	Cases	Binders
One	\$ 8.95	\$11.25
Three	\$24.95	\$31.85
Six	\$45.95	\$60.75
Add \$1.50 per case/binder for postage and handling. Outside USA \$3.50 per case/binder. (U.S. funds only)		

Credit cards accepted: AMEX, Visa, MasterCard, Diners Club (Min. \$15) PA
Residents add 7% sales tax Allow 4 to 6 weeks delivery

Electronic Servicing & Technology
Jesse Jones Industries, Dept. 95 EST
499 East Erie Avenue, Phil., PA 19134
Call TOLL FREE 7 days, 24 hours
1-800-825-6690



ES&T Presents Computer Troubleshooting & Repair

Features information on repairing Macintosh computers, a CD-ROM primer, and a color monitor. Also included are hard drive repair tips and computer diagnostic software.

61087 • \$24.95

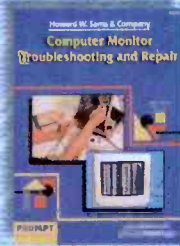

Computer Monitor Troubleshooting & Repair

Learn the basics of computer monitors with chapters on tools and test equipment, monitor types, special procedures, how to find a problem, and how to repair faults in the CRT.

61100 • \$34.95



1999 Computer Monitor Troubleshooting Tips

Includes over 2,000 troubleshooting and repair tips listed by manufacturers name and model number featuring such major names as Apple, Gateway, Compaq, IBM, and Dell.

CD-ROM Included
61179 • \$49.95



ES&T Presents the Test Equipment Guide

Includes the latest information on how to choose the best equipment, how to build test equipment and accessories, how to set up the ideal service bench, and how to put together a practical tool kit.

61089 • \$24.95



Complete VCR Troubleshooting & Repair

In addition to troubleshooting procedures, this book contains nine detailed VCR case studies, each focusing on a particular model of VCR with a very specific and common problem.

61102 • \$34.95



Semiconductor Cross Reference, 4th Edition

With more than 490,000 part numbers, type numbers, and other identifying numbers listed, technicians will have no problem locating the replacement or substitution information needed.

61080 • \$29.95
Also available on CD-ROM,
61140 • \$29.95



ES&T Presents TV Troubleshooting & Repair

Presents important and new information that will make it possible for technicians, students, and electronics hobbyists to service TVs faster, more efficiently, and more economically.

61086 • \$24.95

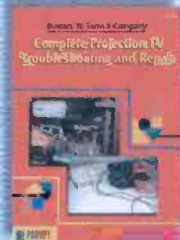

Complete Projection TV Troubleshooting & Repair

Covers everything from the basics of projection circuits, tools and test equipment, TV types, safety procedures and measurements, to the finely detailed repair techniques.

61134 • \$34.95

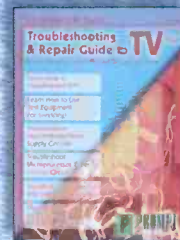

Troubleshooting & Repair Guide to TV, Second Edition

The most comprehensive, complete, and up-to-date television repair book available, with tips on how to troubleshoot the newest circuits in today's TVs.

61146 • \$34.95



ES&T Presents VCR Troubleshooting & Repair

This book provides in-depth and thorough information on a variety of VCR troubleshooting and repair areas.

61158 • \$24.95



Howard W. Sams Service Series RCA/GE Televisions

From RCA component numbering systems to the infamous "tuner wrap" problem, this book gives you all you need to make more efficient repairs.

61171 • \$34.95

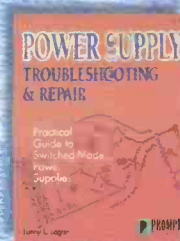

Power Supply Troubleshooting & Repair

Designed to provide technicians with a better understanding of how switched-mode power supplies operate. It also provides practical, useful procedures to follow when troubleshooting power supplies.

61138 • \$24.95

TO ORDER TOLL FREE CALL 1-800-853-9797

When ordering books please include the following information: Name, address, city, state & zip. Please make a list of the books you're requesting. When paying by credit card send the number along with the expiration date. Check, Money Order, Mastercard, VISA, Discover and AMEX accepted. Please make your check or money order payable to: Electronic Servicing & Technology.

U.S. and possessions - add \$4 shipping/handling. **FREE** shipping/handling on orders \$50 and over. Foreign - shipping/handling charges are calculated by order, weight & destination. A \$4 credit will be applied for Foreign orders over \$50.

Please mail your orders to:
Electronic Servicing & Technology
25 Newbridge Road, Hicksville, New York 11801 FAX 516-681-2926



Exact Semiconductors

The Right Parts For The Job

“Trust Me!”

How many times have you heard that!

You built your reputation on hard work and quality repairs. Why change now?

Put your reputation on the line with two names you *can* trust.

SK Series and Thomson Consumer Electronics.

With over 1,700 exacts in stock, you won't have to look anywhere else. And when you're in need of any video heads, belts, tires, flyback transformers or video replacement parts, we have them too.

But we don't stop there.

Our continuing quality assurance and accuracy goes into every SK Series product.

For more information on SK Series products, contact your nearest Thomson Distributor.

SK Series...The parts you need to do the job. “Trust me!”

 THOMSON CONSUMER ELECTRONICS



SK
Series

Circle (113) on Reply Card